



# CARGO COVER/EQUIPMENT TRAY (SRS)

2020+ FORD PI UTILITY

Installation Instructions

475-1865

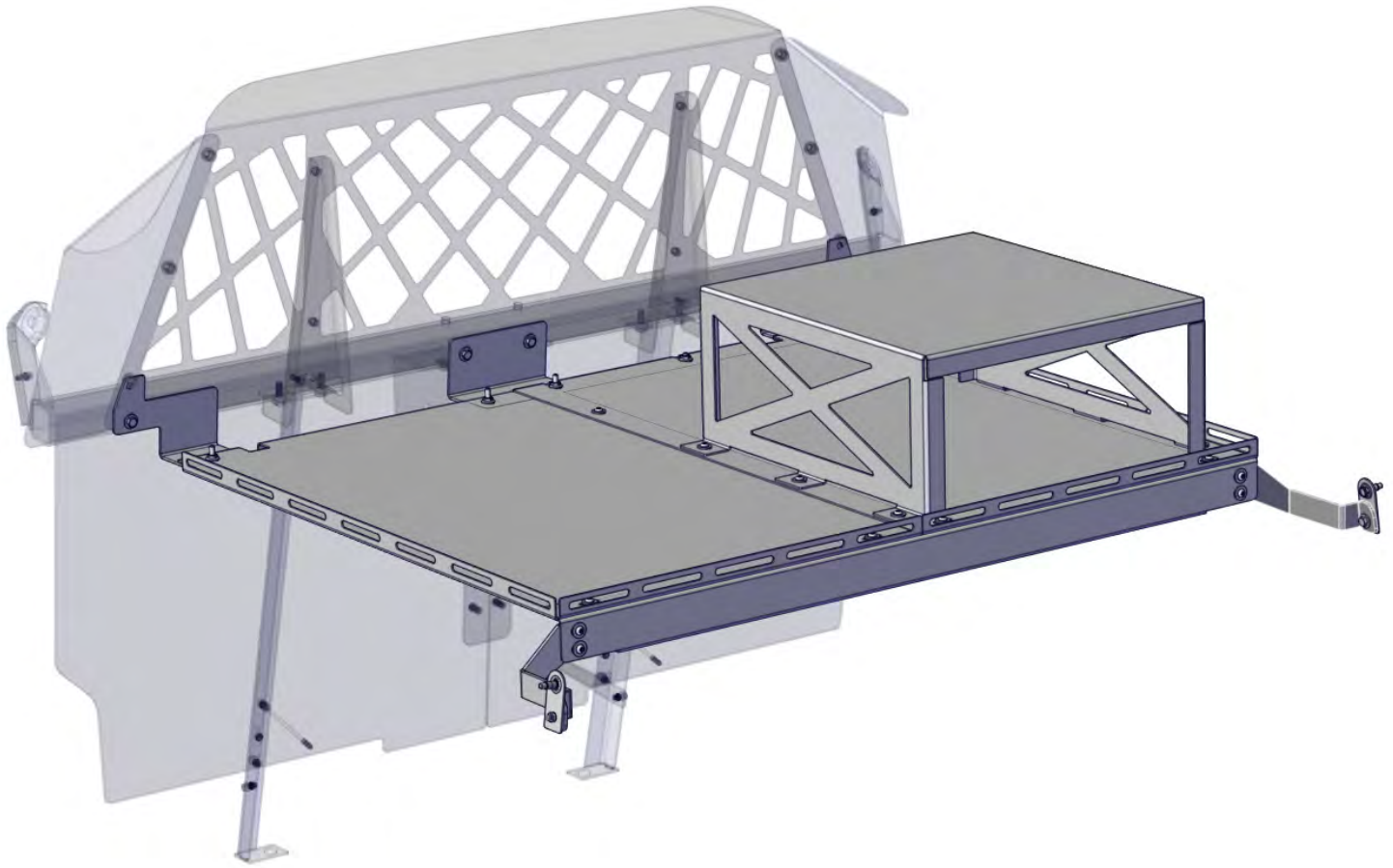

Before beginning the installation, confirm that you have received all of the parts for your package. Read the instructions completely before starting installation. **Intall Seat Replacement System first.**

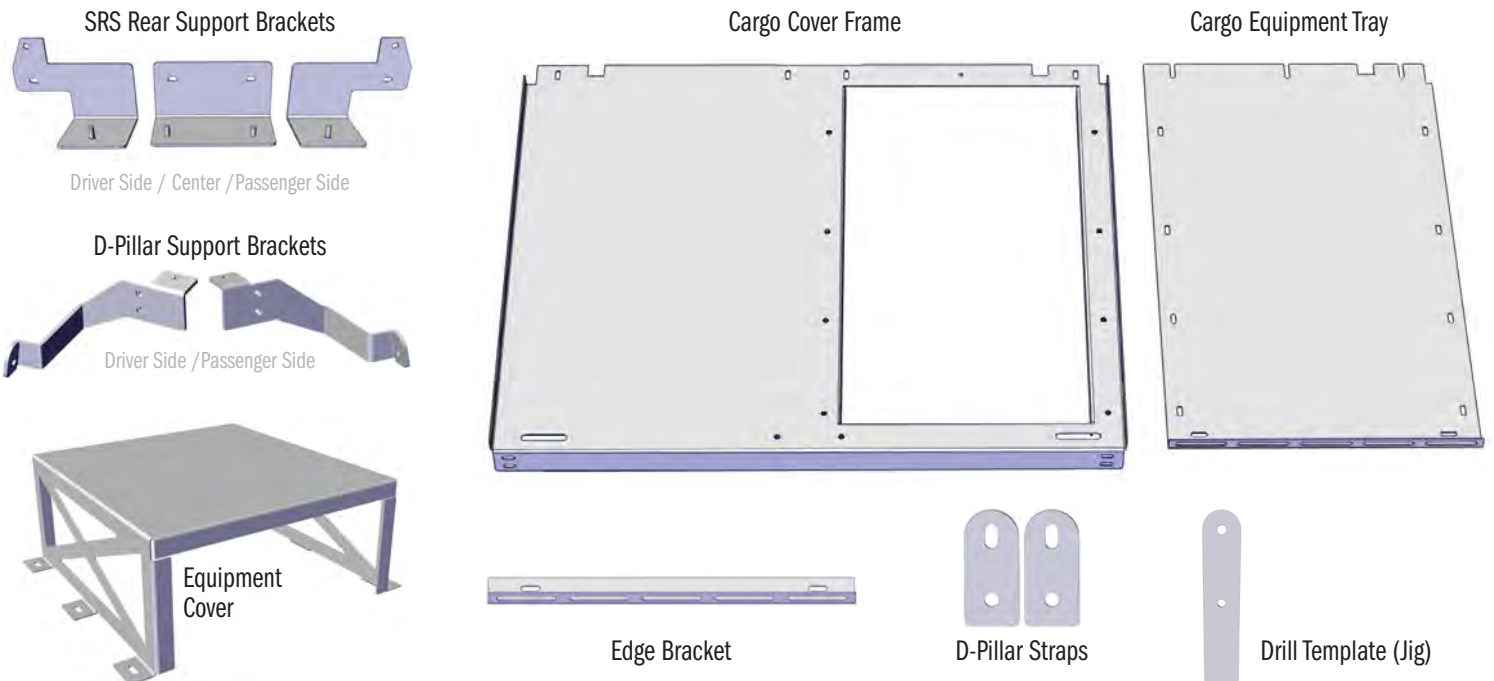

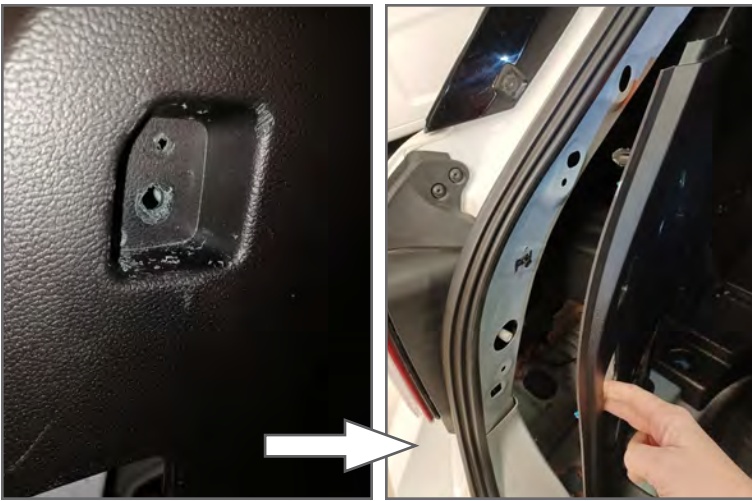

1. Unscrew the (2) OEM Trunk Cargo Net Tie-Down Hooks and pop loose the D-pillar trim. Drill OEM trim mounting hole to 9/32".

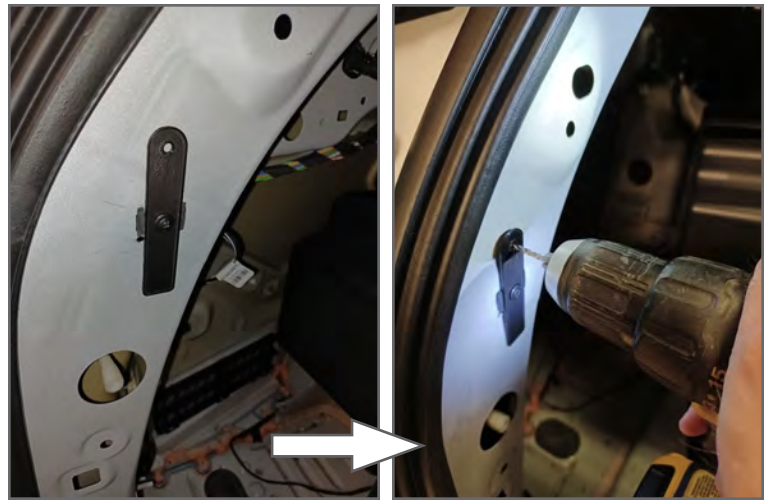

2. Use the previously removed OEM screw to attach the drill template (Jig) to ensure proper placement of the AVK fastener. Be sure the Jig is perfectly vertical before drilling 1/8" pilot hole followed by a 25/64 finished hole.

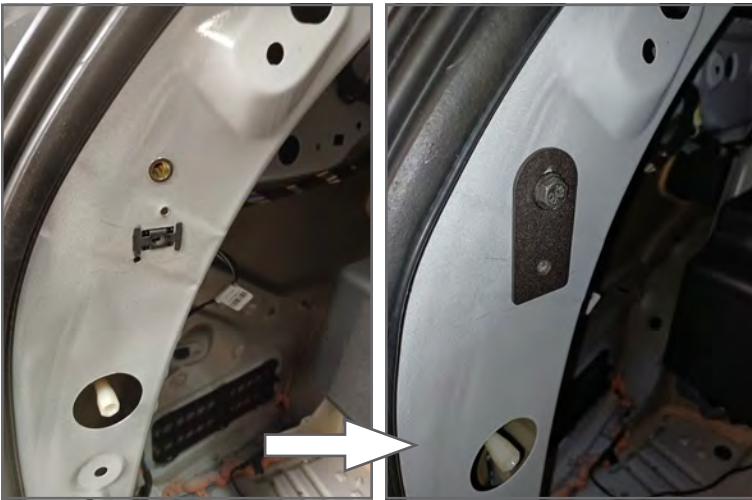

3. Drill or pop out the OEM mounting clip that held the Jig in place. Install AVK fastener and attach the Driver Side and Passenger Side D-Pillar Straps. Replace OEM trim.

**(AVK FASTENER INSTALL STEPS ON LAST PAGE)**

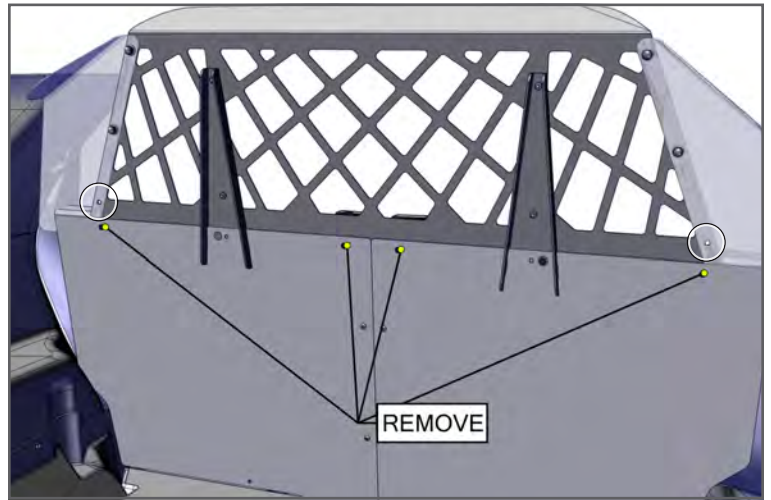

4. Remove (4) 1/4-20 Socket Head Cap Screws attaching the Cargo Cover to the Top Bar and the lower mounting hardware securing the Driver Side and Passenger Side Poly Wings.

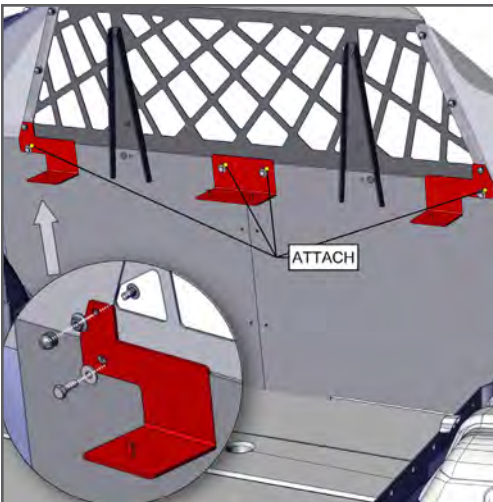

5. Attach the Driver Side, Center, and Passenger Side Rear Support Brackets with (4) 1/4-20 x 3/4 Bolts and Washers. Secure the upper mounting holes of the Driver Side and Passenger Side Support Brackets on top of the Upper Poly Wings with the previously removed hardware.

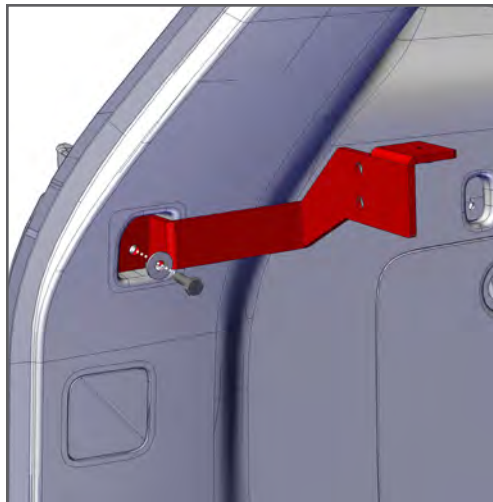

6. Secure the Driver Side and Passenger Side Front Support Brackets with (2) 1/4-20 x 3/4 Bolts and Washers.

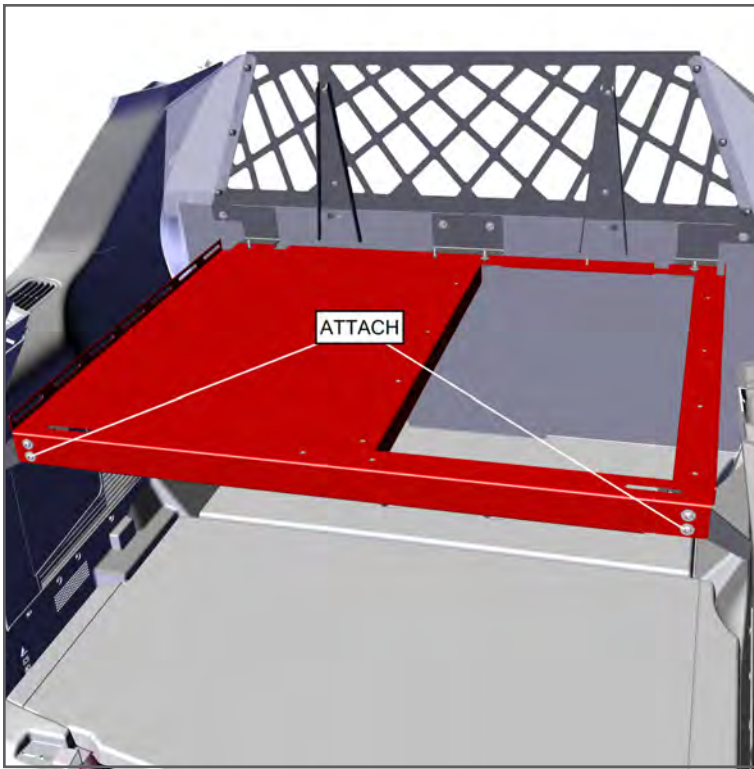

7. Insert the Cargo Cover into the vehicle resting on top of the Front and Rear Support Brackets. Secure the front of the Cargo Cover to the Front Support Brackets with (4) ¼-20 x 5/8 Button Head Cap Screws and Washers.

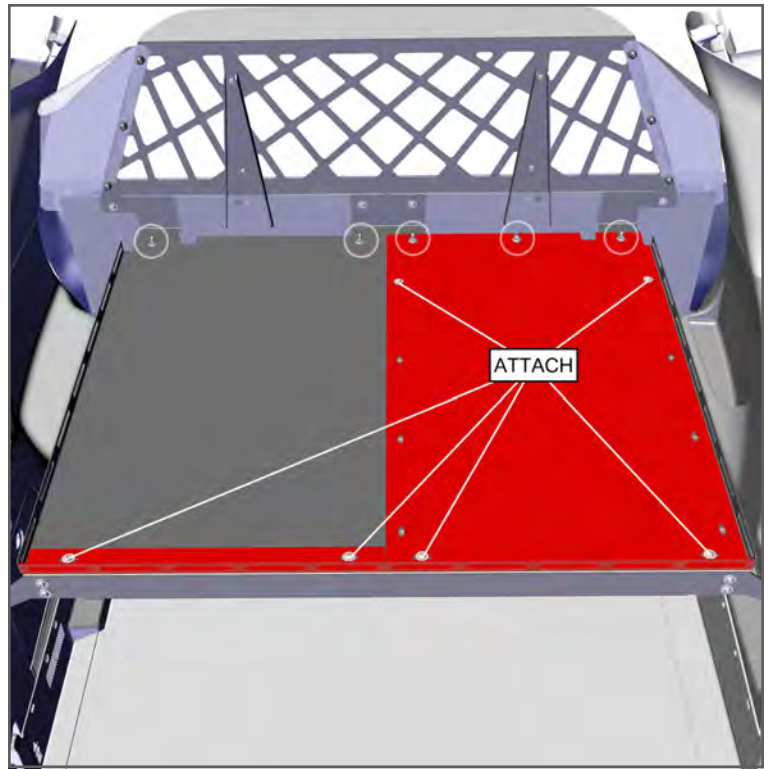

8. Insert the removable Equipment Tray and Edge Bracket. Secure to the Cargo Cover with (6) ¼-20 x 5/8 Button Head Cap Screws and Washers, and to the Rear Support Brackets with (5) Flange Nuts.

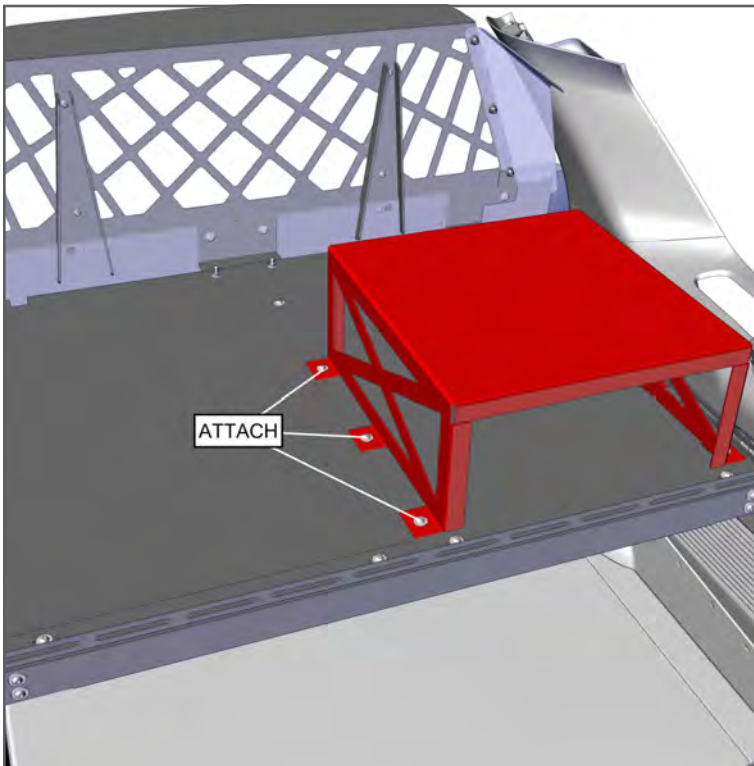

9. After equipment is secured to the Equipment Tray, attach the Equipment Cover with (6) ¼-20 x 5/8 Socket Head Cap Screws and Washers.

If you have questions or need further assistance please call Technical Support: 1.877.455.6886



209 W. EASY ST., ROGERS, AR 72756 • JOTTOPUBLICSAFETY.COM • 9/24

Jotto Desk™ is a patented product and Registered Trademark of Assembled Products™ Corporation.  
Specifications subject to change without notice.

050-0089-00



# AVK FASTENER INSTALLATION INSTRUCTIONS



AVK Installation video can be viewed at:  
<http://jottopublicsafety.gojotto.com/additional-categories/downloads.html>



1. Drill out existing hole to 1/2" or drill new hole per installation instructions.



2. Place 5/16-18 x 1.5" long bolt through the 3/8" flange nut and hand thread bolt into the AVK Fastener.



3. Place into 1/2" drilled hole.

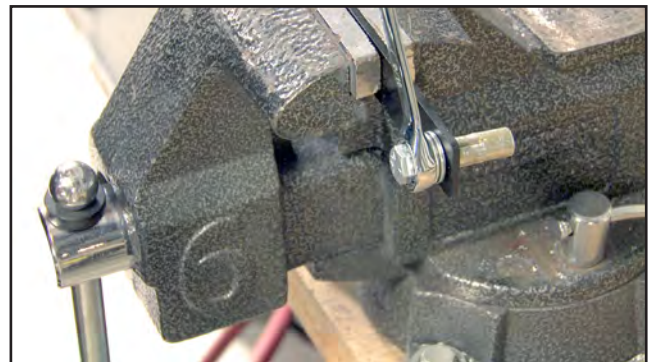

4. Use 9/16" box end wrench to secure the flange nut.



5. Apply pressure on the flange nut, pressing AVK Fastener into hole.

6. Using an air wrench, tighten the 5/16-18 x 1.5" bolt.



7. This will allow the AVK Fastener to secure onto the backside of the metal.

8. Remove 5/16-18 x 1.5" bolt.

If you have questions or need further assistance please call Technical Support: 1.877.455.6886



209 W. EASY ST., ROGERS, AR 72756 • JOTTOPUBLICSAFETY.COM • 9/24

Jotto Desk™ is a patented product and Registered Trademark of Assembled Products™ Corporation.  
Specifications subject to change without notice.

050-0089-00

