



# MAX DEPTH CONTOUR CONSOLE

## FORD PI UTILITY 2020+

### Installation Instructions

425-6512

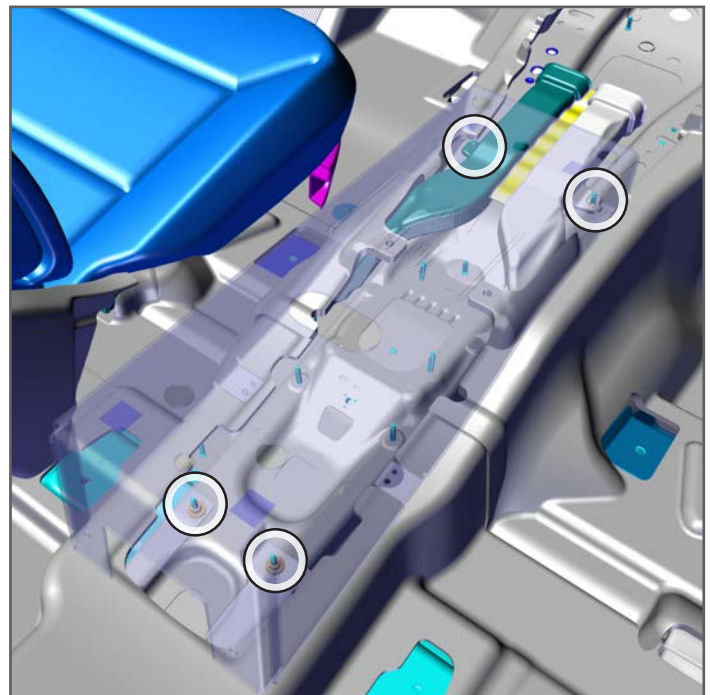
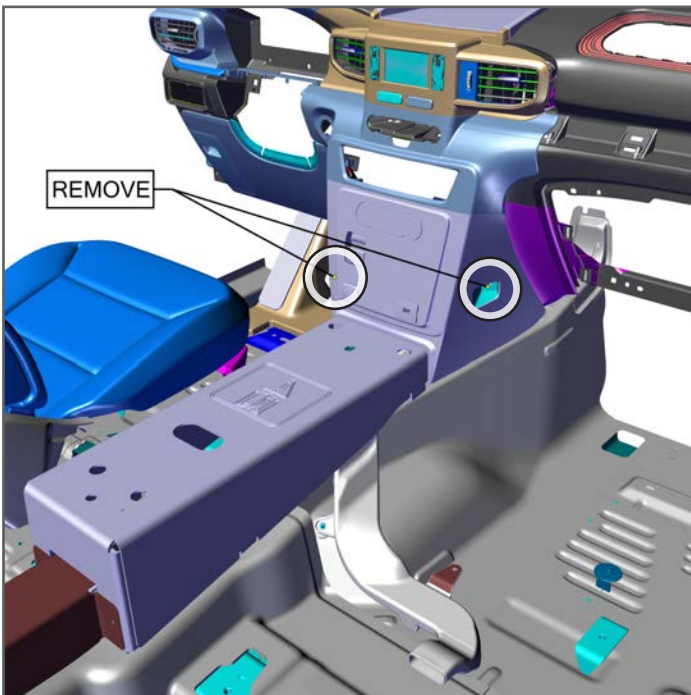

1. Unscrew lower OEM trim. Keep hardware for Max Depth Contour Console.
2. Remove lower OEM trim by disconnecting the 12v Power, USB, Parking Brake and Rear Air Control for relocation into the Max Depth Contour Console.
3. Remove the factory OEM front and rear 10 mm nuts holding the OEM Cover Plate in place.
4. Remove Cover Plate from vehicle. It will not be utilized.

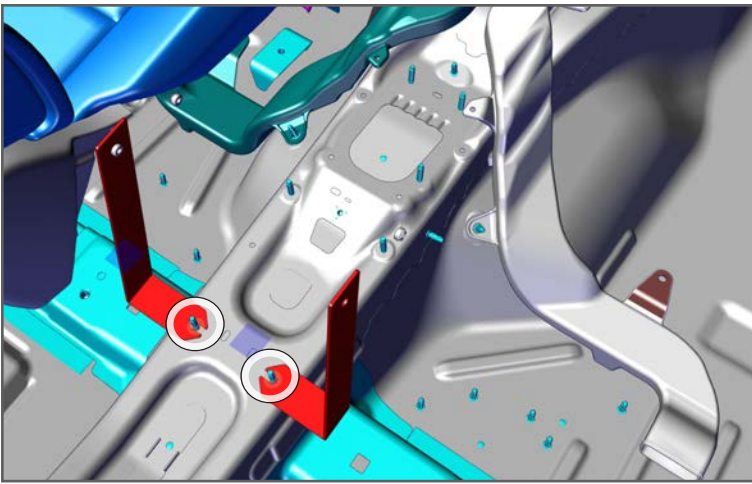

5. Attach the Rear Mount Legs to existing studs with provided hardware.

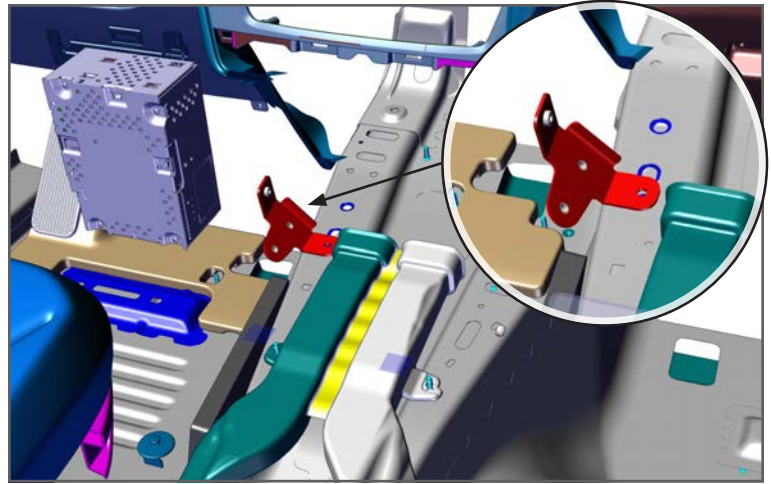

6. Remove D/S front OEM 10 mm screw and attach D/S Front Bracket.

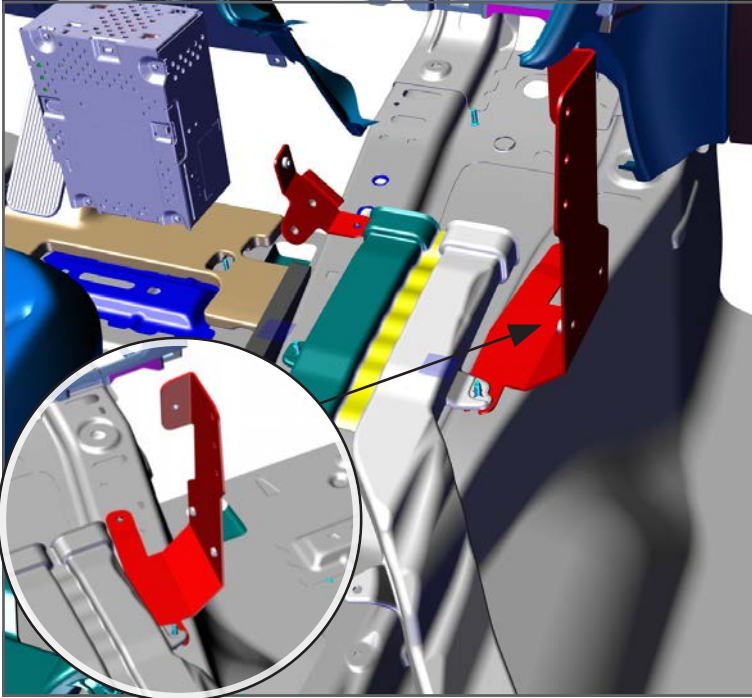

7. Attach the P/S front bracket by detaching the OEM radio and moving it to the left. Secure the D/S front brackets rear mounting hole to the stud, under the air ducts mounting tab with previously removed 10 mm nut, and front mounting hole with provided hex head tapping screw.

8. With the radio moved aside secure the front hole with provided self-drilling screw.

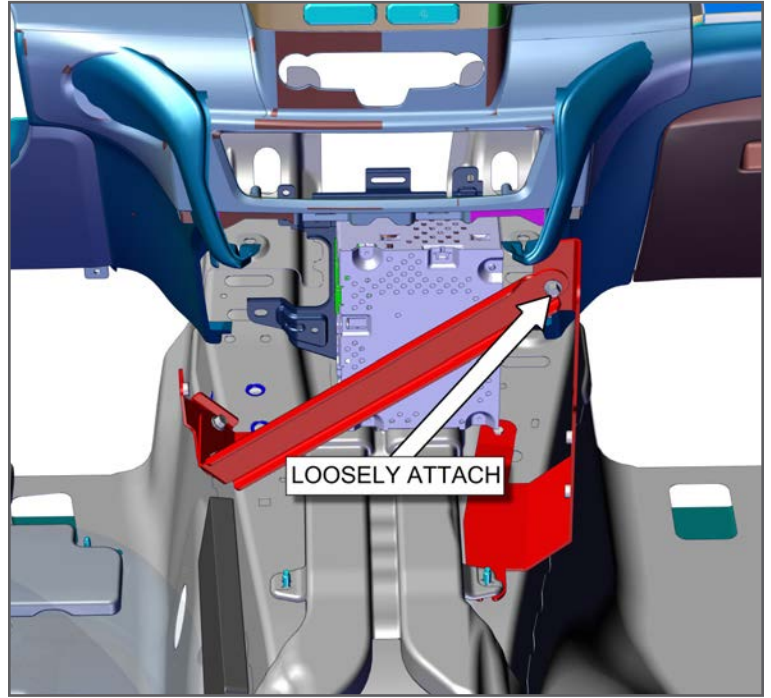

9. Replace radio.

10. Loosely attach Cross Brace to DS/PS Front Brackets with provided hardware.

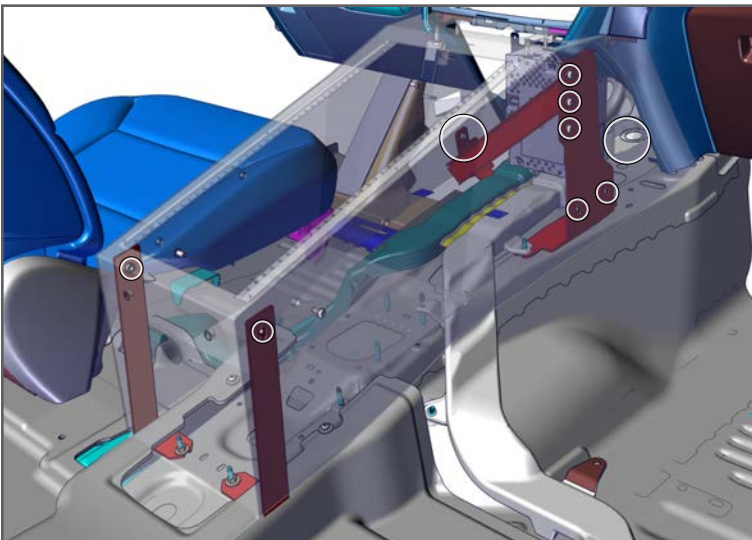

11. Position the Console into the vehicle aligning the mounting points on the Rear Mounting Legs and to the OEM Dash Structure.

12. With provided hardware secure the Console to the previously attached Front and Rear Mounting Brackets and to the OEM Dash Structure with OEM screws. Fully secure Cross Brace and tighten all remaining hardware..

*(4 points for IPB Contour Console with OEM hardware;  
9 points if using provided hardware.)*

**If you have questions or need further assistance  
please call Technical Support: 1.877.455.6886**