

425-8001

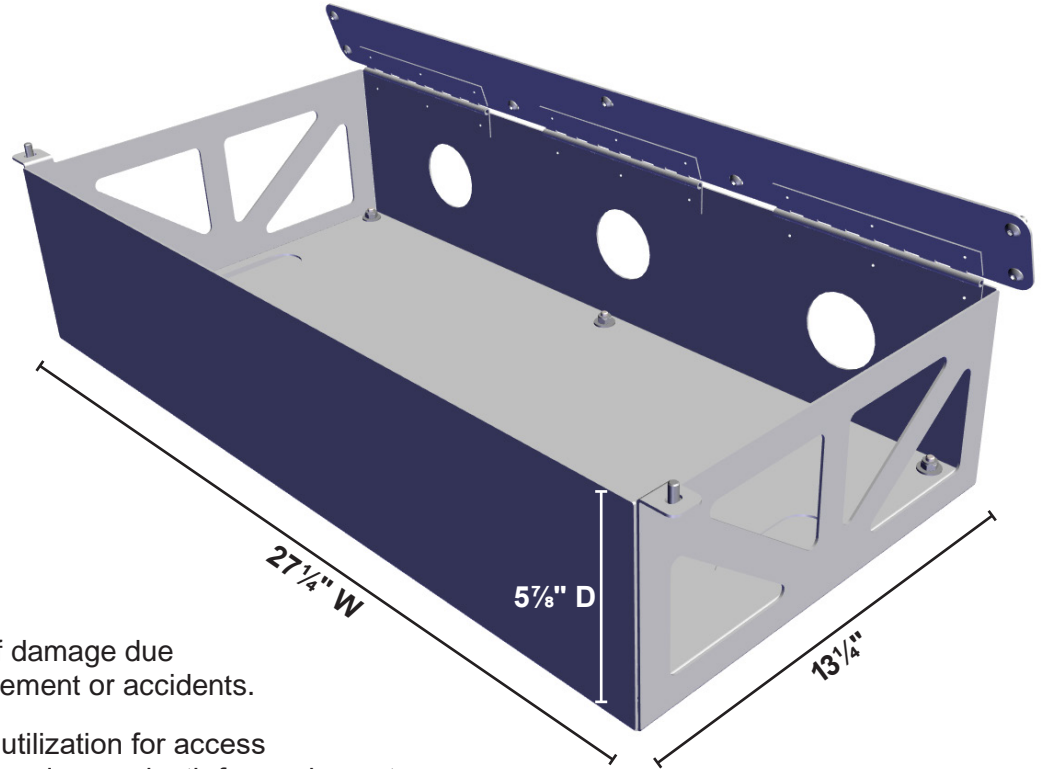

# Ford PI Utility (2020+) Cargo Barrier Equipment Tray



## DETAILS

Width ..... 27 1/4"  
 Height ..... 13 1/4"  
 Depth ..... 5 7/8"  
 Weight..... 28 1/2 lbs.

- Unique design reduces the risk of damage due to loose items during vehicle movement or accidents.
- Heavy duty design offers optimal utilization for access to equipment mounted to the tray and more depth for equipment.
- Designed to mount to the 475-0067 or 475-1337 Cargo Barriers.
- Design allows equipment to be externally mounted to Removable Shelf, bench tested and installed easily.
- 2" round openings for routing wires/cabling.
- Includes Removable Shelf.  
(pictured below)

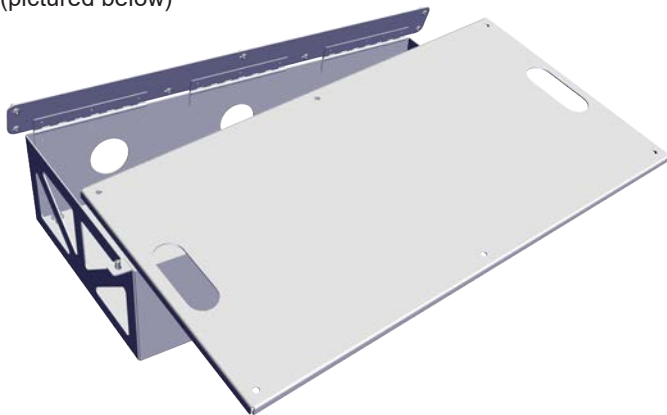

## ORDER

**Model No.**

**425-8001** ..... Ford PI Utility (2020+)



209 W. EASY ST., ROGERS, AR 72756 • www.EVERYTHINGBUTLIGHTS.com • 9/19

Jotto Desk® is a patented product and Registered Trademark of Assembled Products™ Corporation. Contour Console™ has design and utility patents. Additional Patents Pending. Specifications subject to change without notice.