



CB4 CARGO BARRIER

2020+ FORD PI UTILITY | SCA COMPLIANT

Installation Instructions

CB4 Cargo Barrier - 475-0067

CB4 Cargo Barrier with Poly Cover - 475-1337

Before beginning the installation, confirm that you have received all of the parts for your package.
Read the instructions completely before starting installation.



TOOLS NEEDED:

- Ratchet
- 7/16" Socket
- 3/16" Hex Key Socket
- 5/32" Hex Key Socket
- 9/32" Socket
or Phillips-head Screwdriver
- 13 mm Socket
- 18 mm Socket
- T55 mm Torx Bit Socket

PARTS INCLUDED:

- Hardware Bag with
necessary nuts, bolts, etc.



Outer Mount
Brackets



PS

Wings

DS



Support
Tubes



PS

DS

Rear Mount Legs



PS

Side Wings

DS



Poly Cover (475-1337 only)

*** SEATS MUST REMAIN UPRIGHT DURING INSTALLATION**



1. Remove OEM flooring starting at the hatch. This portion can simply be pulled out.
2. Remove the (2) bolts to remove forward flooring and set aside for replacement.

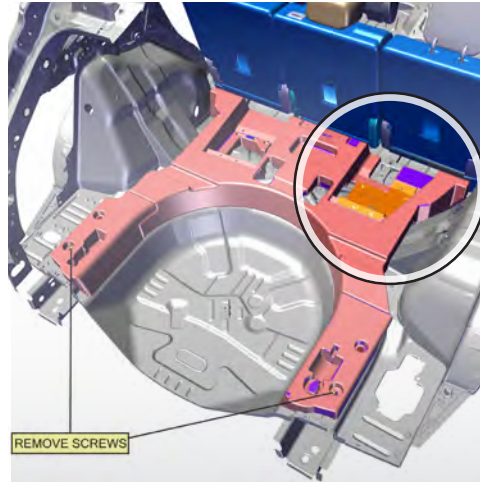

3. Remove the (2) 8 mm OEM bolts holding the end pieces in place.
4. Unclip the wire harness and remove the cover plate to remove the upper foam from the vehicle. Once Cargo Barrier is installed, this will be reinstalled into vehicle.
5. Remove OEM solid foam core from cargo area in 2 sections.



6. Install DS/PS Outer Mount Brackets to the OEM 13 mm rear seat bolts and the DS/PS Rear Mount Legs into vehicle by removing OEM 18 mm Bolts located on the lower rear cross brace.

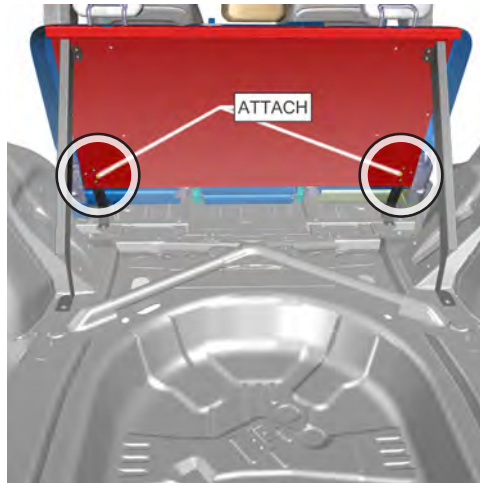

7. Install Lower Steel Barrier through rear of vehicle.
8. Attach the Barrier to the previously installed DS/PS Outer Mount Brackets with provided Button Head Cap Screws. The DS/PS Rear Mount Legs will support Lower Steel Barrier.

*** DO NOT ATTACH YET.**

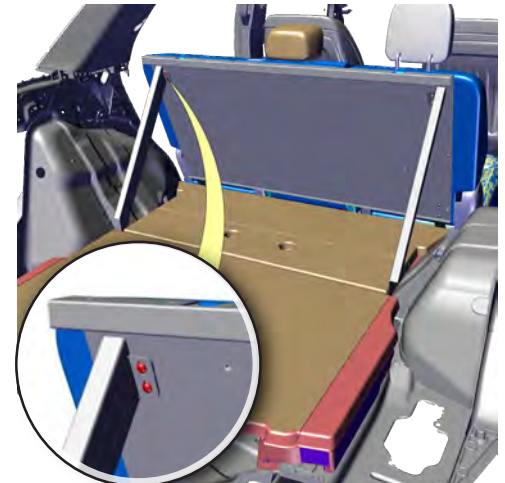

9. Reinstall OEM solid foam core and OEM flooring. Secure in place with previously removed (2) OEM bolts.
- * You can now attach DS/PS Rear Mount Legs to Lower Steel Barrier with provided Button Head Cap Screws.*

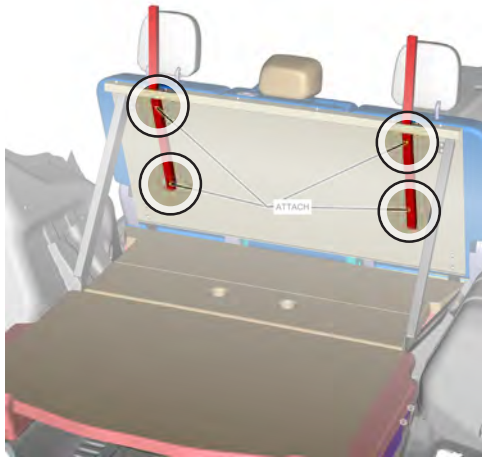

10. Insert and secure Support Tubes to the Lower Steel Barrier from cargo side.

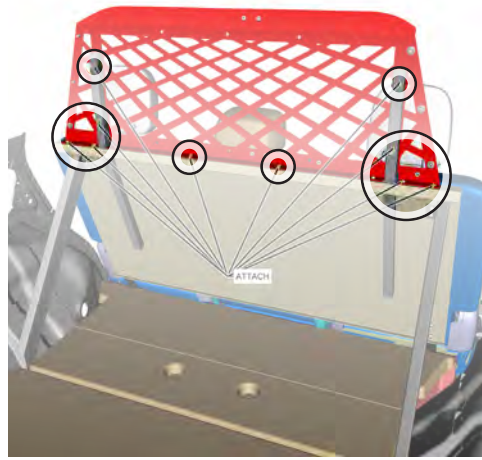

11. From rear seat of vehicle, use button head cap screws to attach Secure Grid to Lower Steel Barrier and (4) carriage bolts and flange nuts to the Support tubes.

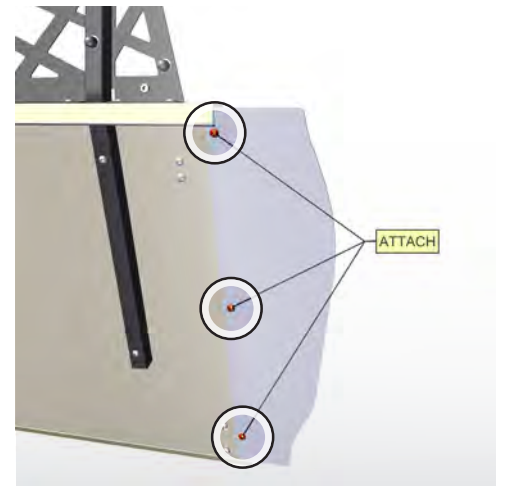

12. Install Lower PS/DS Side Wings with provided hardware to the rear side of the cargo barrier.

* For Poly Cover (475-1337), installation instructions see below.

475-1337

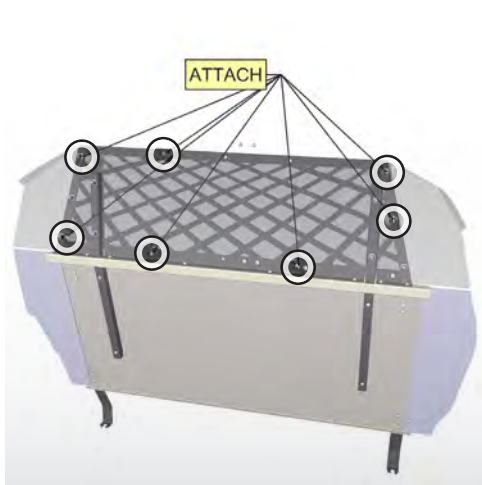

13. From rear seat of vehicle, use (16) carriage bolts and flange nuts to attach the Poly Cover to the front of the Secure Grid and Support tubes.

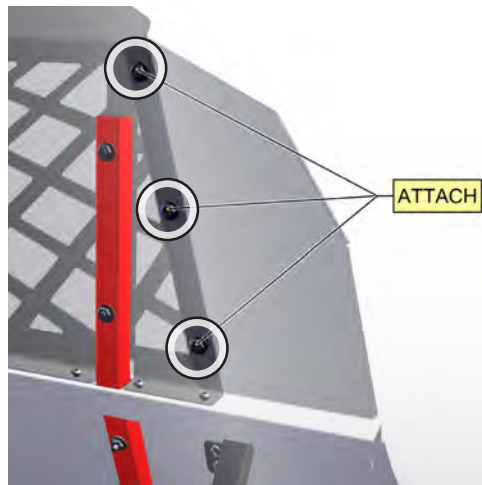

14. Install Side Poly Wings through rear of vehicle. Secure with (3) carriage bolts with flange nuts.

If you have questions or need further assistance please call Technical Support: 1.877.455.6886



209 W. EASY ST., ROGERS, AR 72756 • JOTTOPUBLICSAFETY.COM • 9/24

Jotto Desk™ is a patented product and Registered Trademark of Assembled Products™ Corporation.
Specifications subject to change without notice.

050-0084-00

