



SINGLE CELL

2020+ FORD PI UTILITY

Installation Instructions

475-0767

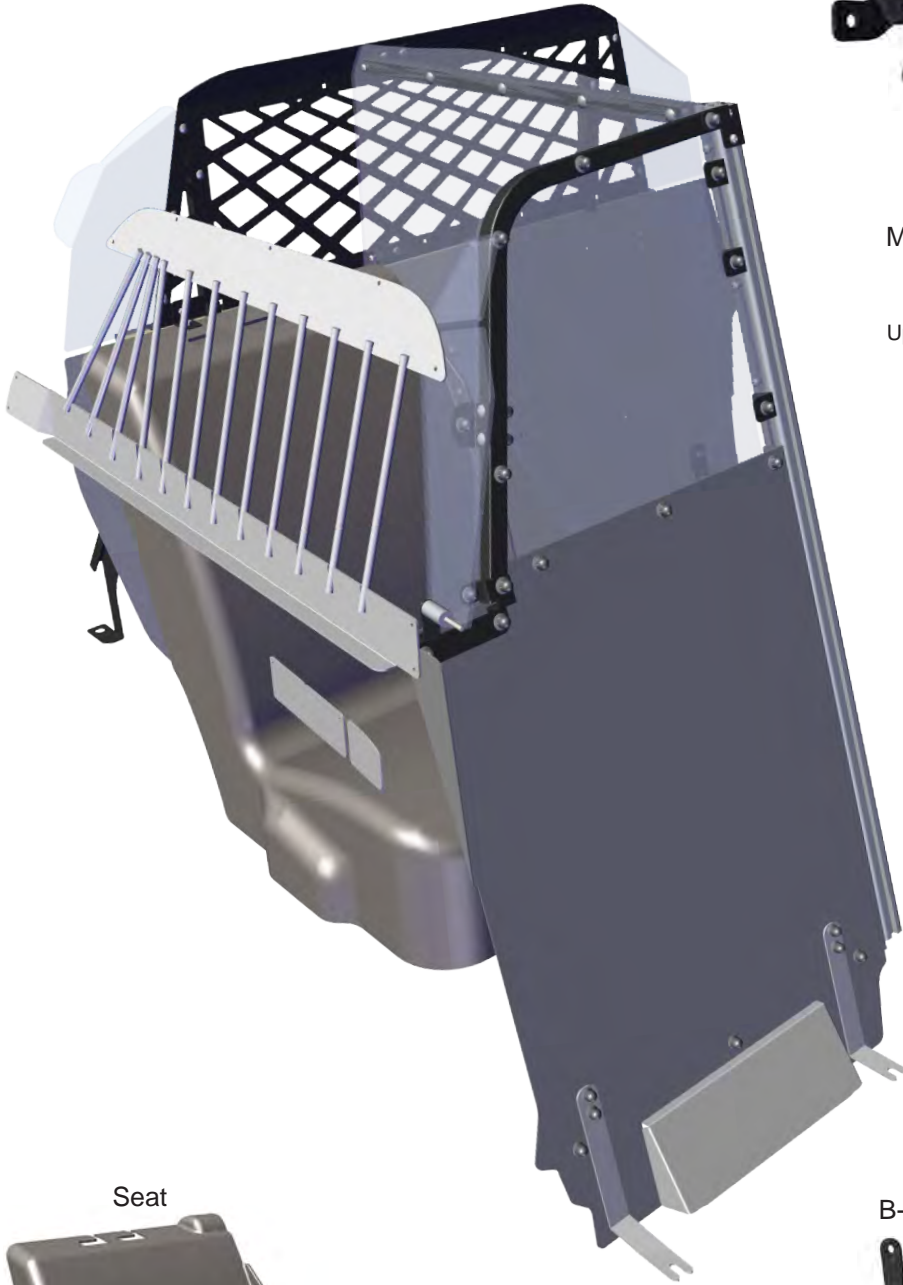

Tube Brackets



Center Stiffener Tubes

Mount Brackets



Upper



Lower

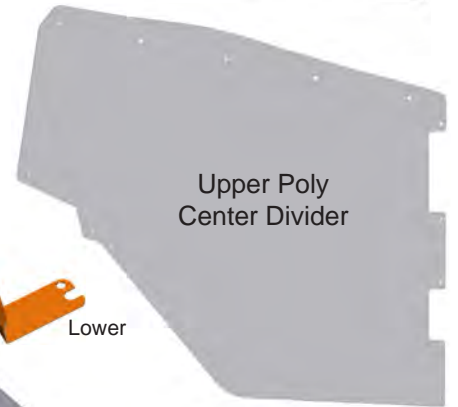

Upper Poly Center Divider



Lower Steel Center Divider

Poly Wing



B-Pillar Bracket



Assembled Front Divider

Mounting Feet



Outside Foot



Inside Foot



Seat



HSEP

INSTALL CARGO BARRIER NOW

* SEATS MUST REMAIN UPRIGHT DURING INSTALLATION

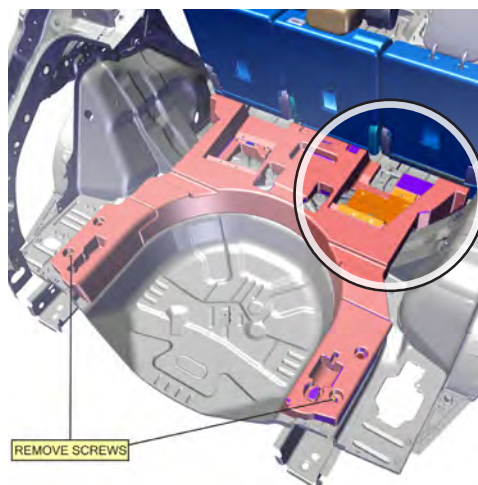

1. Remove OEM flooring starting at the hatch. This portion can simply be pulled out.
2. Remove the (2) bolts to remove forward flooring and set aside for replacement.

3. Remove the (2) 8 mm OEM bolts holding the end pieces in place.
4. Unclip the wire harness and remove the cover plate to remove the upper foam from the vehicle. Once the Cargo Barrier is installed, this will be reinstalled into vehicle.
5. Remove the OEM solid foam core from cargo area in 2 sections.

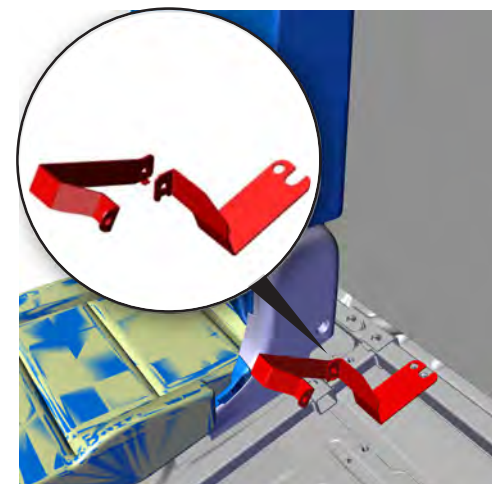
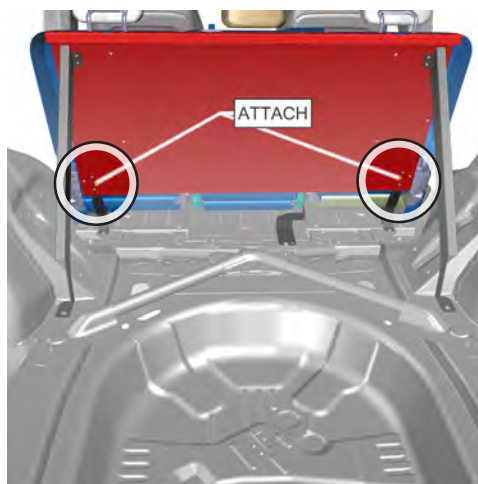

6. Install DS/PS Outer Mount Brackets to the OEM 13 mm rear seat bolts and the DS/PS Rear Mounts Legs into vehicle by removing OEM 18 mm bolts, located on the vehicles lower rear cross brace.
7. Install the Single Cell Lower Mount Bracket to the OEM cross tube with existing 15 mm bolt.

8. Install the Lower Steel Barrier through rear of vehicle.
9. Attach the Barrier to the previously installed DS/PS Outer Mount Brackets with provided button head cap screws. The DS/PS Rear Mount Legs will support Lower Steel Barrier.

10. Insert the Single Cell Upper Mount Bracket in-between the rear seats from the Passenger side.
11. Attach to the Lower Mount Bracket to the Upper Mount Bracket from the cargo area with provided hex bolt.

* **DO NOT ATTACH YET.**

CARGO BARRIER 475-0067

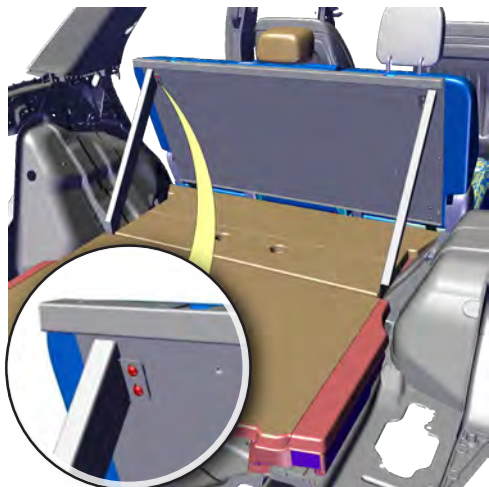

12. Reinstall OEM solid foam core and OEM flooring. Secure in place with previously removed (2) OEM bolts.

* *You can now attach DS/PS Rear Mount Legs to Lower Steel Barrier with provided Button Head Cap Screws.*

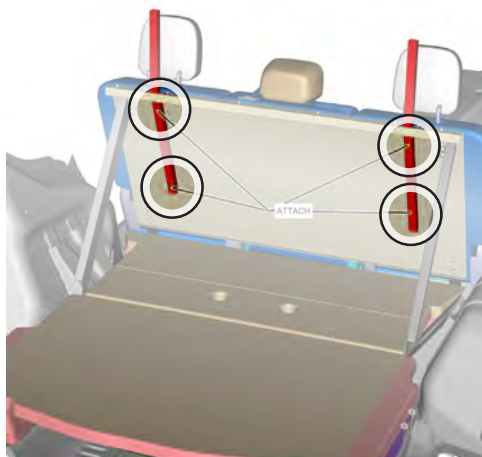

13. Insert and secure Support Tubes to the Lower Steel Barrier from cargo side.

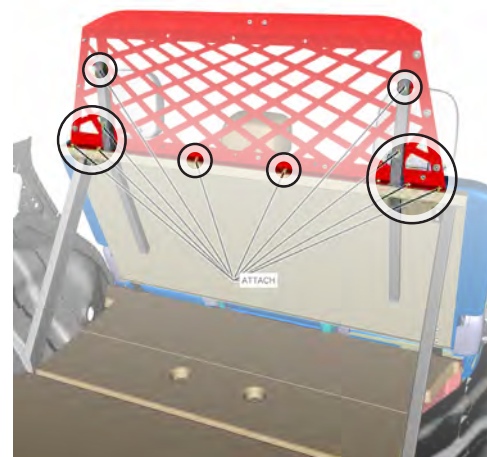

14. From rear seat of vehicle, use button head cap screws to attach Secure Grid to Lower Steel Barrier and (4) carriage bolts and flange nuts to the Support Tubes.

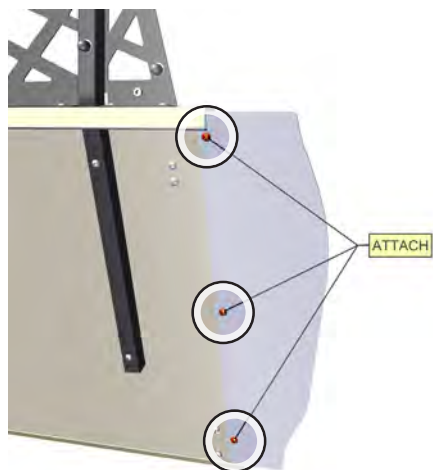

15. Install Lower PS/DS Side Wings with provided hardware to the rear side of the Cargo Barrier.

* *475-0067 installation complete.*

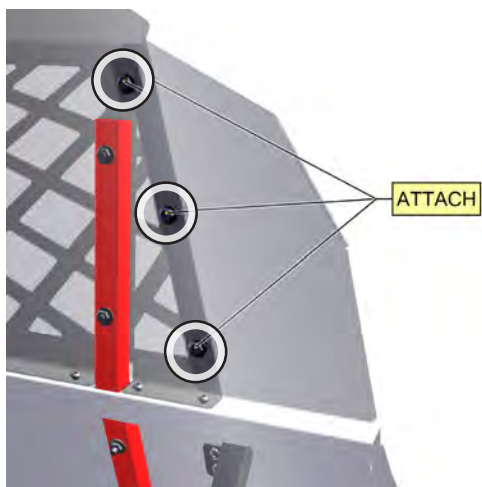

16. Install Side Poly Wings through rear of vehicle. Secure with (3) carriage bolts with flange nuts.

INSTALL SINGLE CELL NOW

(pages 4-5)



1. Loosen the passenger side rear 13 mm seat bolts.

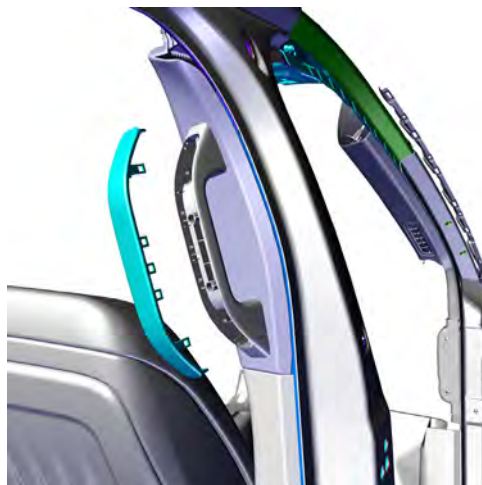

2. Pop the top/bottom cover of P/S rear seat grab handle, exposing (2) 7 mm hex bolts.

3. Remove lower bolt.

* OEM COVERS CAN BE LEFT OFF OR THEY CAN BE TRIMMED DOWN TO BE REINSTALLED.

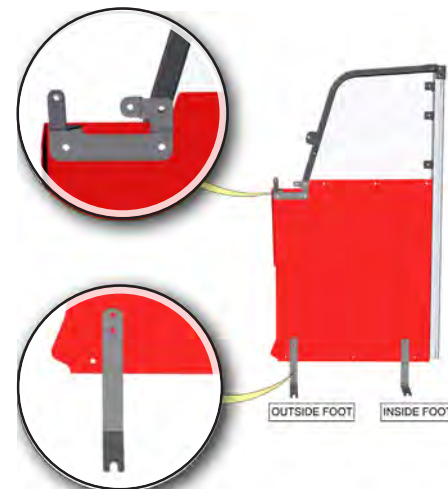

4. Attach the B-Pillar Bracket and Mounting Feet to the Front Divider with provided carriage bolts and flange nuts.

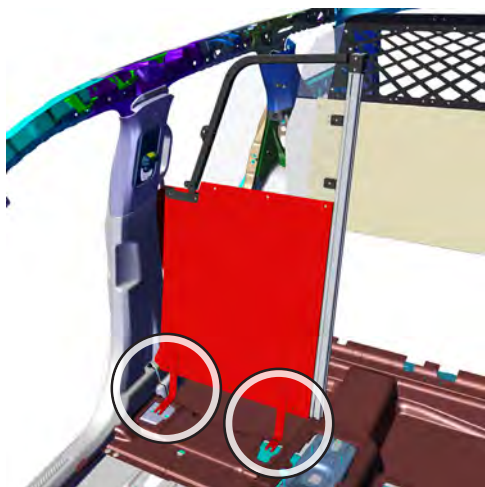

5. Install the Assembled Front Divider into the vehicle through P/S rear door.

6. Insert the Lower Mount Feet under the seat track and align with the rear seat bolts.

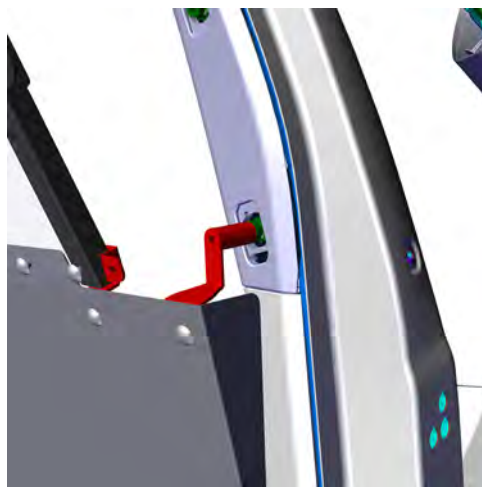

7. Attach B-Pillar Bracket to lower grab handle mount with provided spacer and hardware.

8. Tighten OEM rear seat bolts securing Assembled Front Divider into place.



9. Attach the Support Tube to the D/S of the Lower Steel Center Divider with provided carriage bolts and flange nuts.

* Last hole will not have a carriage bolt until being attached to Upper Mount Bracket previously installed between the seats.

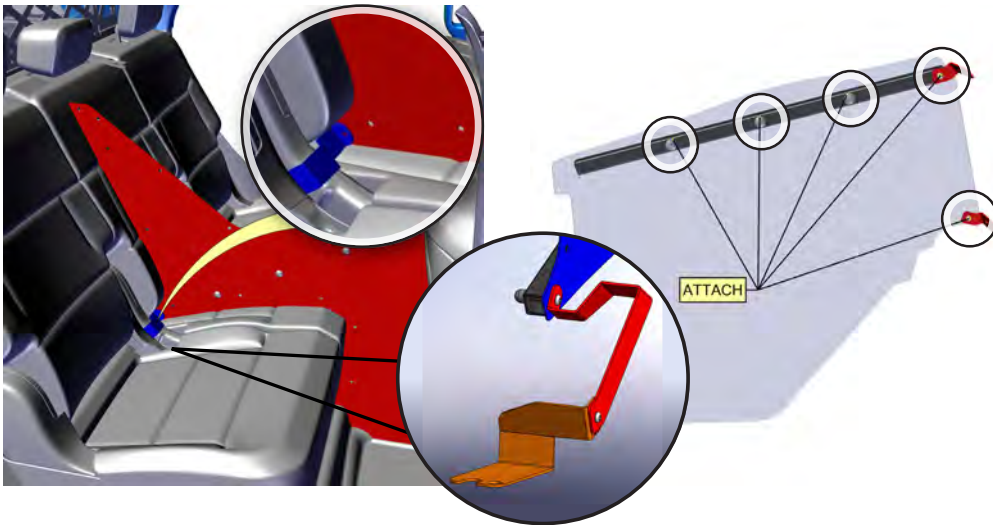

10. Insert the Lower Steel Center Divider into the vehicle through the D/S door, wrapping the tabs around the backbone at the front and securing with button head cap screws.
11. Secure the Lower Steel Center Divider to the Upper Mount Bracket at the rear with carriage bolt and flange nuts.

12. Peel protective film from Upper Poly Center Divider.
 13. Attach Stiffener Tube to D/S of Upper Poly Center Divider using provided carriage bolts and flange nuts.
 14. Secure the Tube Brackets to the end of the Poly Divider and one to the tube with socket head cap screws.
- * Front of the tube will not have hardware until next step.

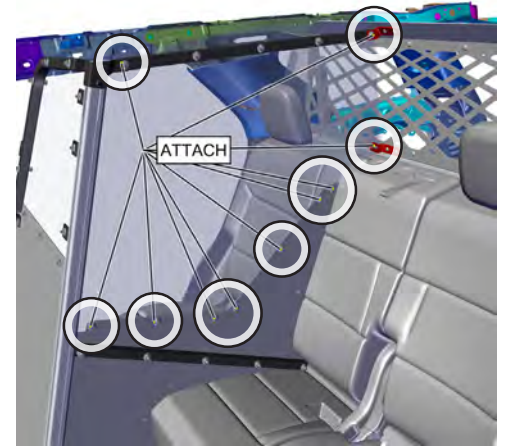

15. Attach Upper Poly Center Divider to the Lower Steel Center Divider with provided carriage bolts and flange nuts.
16. Secure the Tube Brackets to the Cargo Barrier with button head cap screws and the front of the Upper Poly Center Divider Tube to the Assembled Front Divider.



17. Attach Upper Poly Wing to Front Side of Assembled Front Divider near B-Pillar using 1/4-20 carriage bolt and flange nuts in the upper and lower holes of the wing.

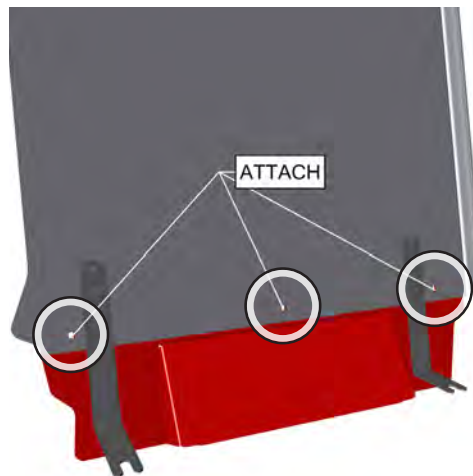

18. Attach the HSEP to the Assembled Front Divider with provided hardware from prisoner compartment.



19. Attach the (2) Upper Seat Window Brackets to the ABS seat with provided (2) 1/2-20 socket head cap screws and 1/4-20 nylock nut.

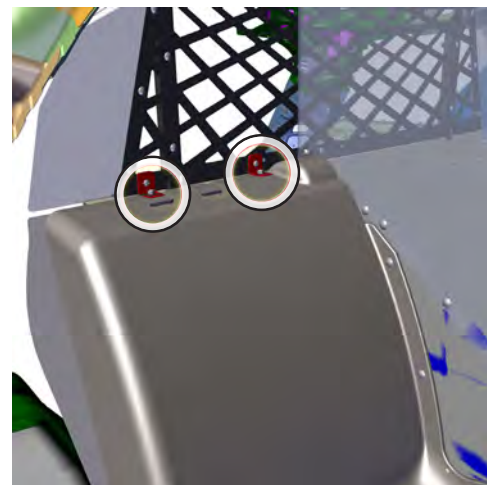
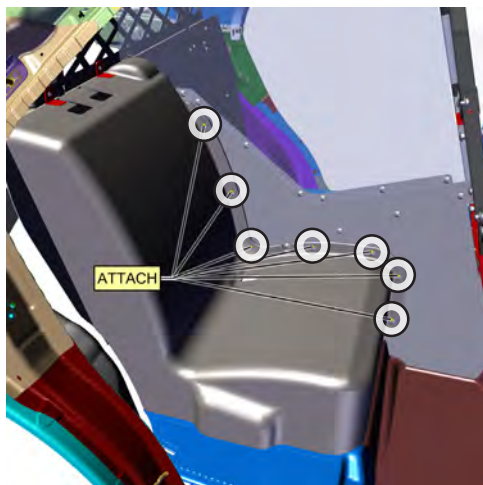
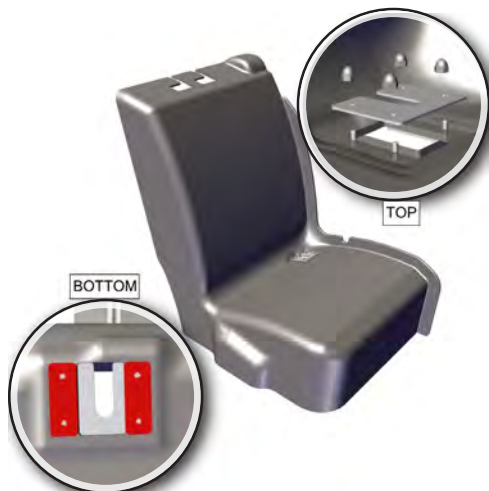

20. From the back side of the ABS Seat push the Backing Plates through the pre-drilled holes.
21. Use tape to secure the Backing Plates in position and place seat into vehicle.
22. Reach under the seat and guide the seat belt through the slot of the ABS seat. Secure in place from the top with provided Seat Belt Retainer and (4) 1/4-20 acorn nuts.

23. Secure the ABS Seat to the Center Lower Steel Divider with provided (7) 1/4-20 carriage bolts and flange nuts.

24. Attach the Upper Seat Window Brackets to the Cargo Barrier with provided (2) 1/4-20 socket head cap screws.

If you have questions or need further assistance please call Technical Support: 1.877.455.6886



209 W. EASY ST., ROGERS, AR 72756 • JOTTOPUBLICSAFETY.COM • 10/24

Jotto Desk™ is a patented product and Registered Trademark of Assembled Products™ Corporation.
Specifications subject to change without notice.

