



REPLACEMENT BIO-SEAT SYSTEM

FORD PI UTILITY 2020+

Installation Instructions

475-0923

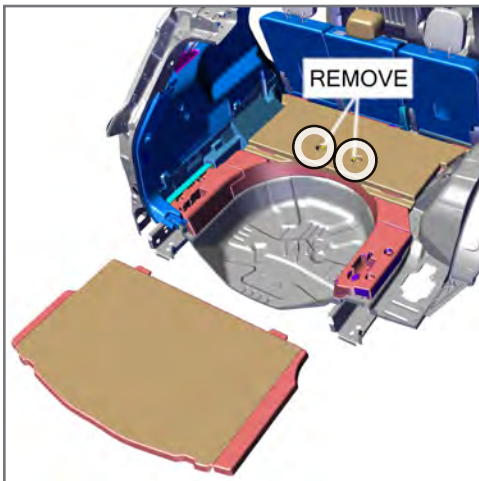
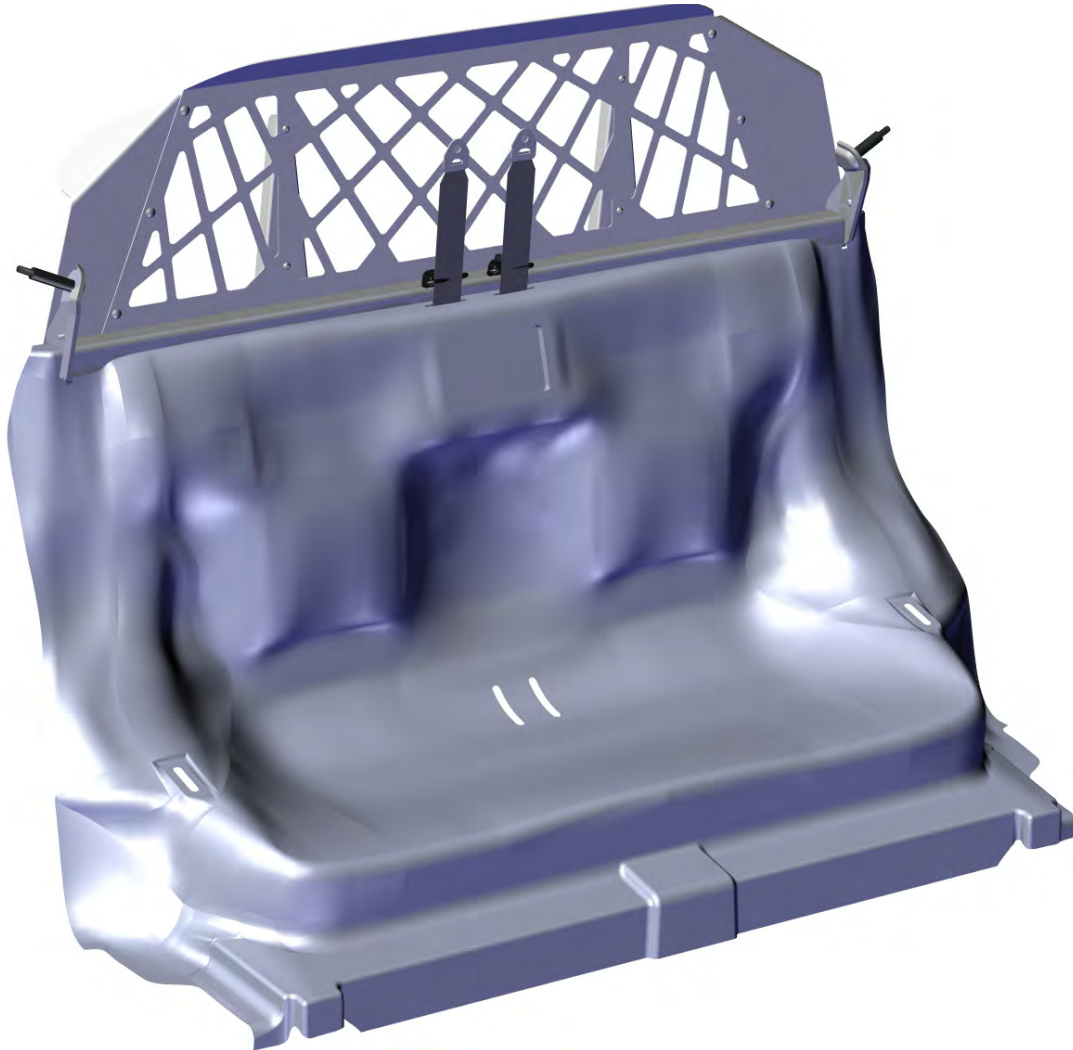

1. Remove OEM flooring starting at the hatch. This portion can simply be pulled out.
2. Remove the (2) bolts to remove forward flooring and set aside for replacement.

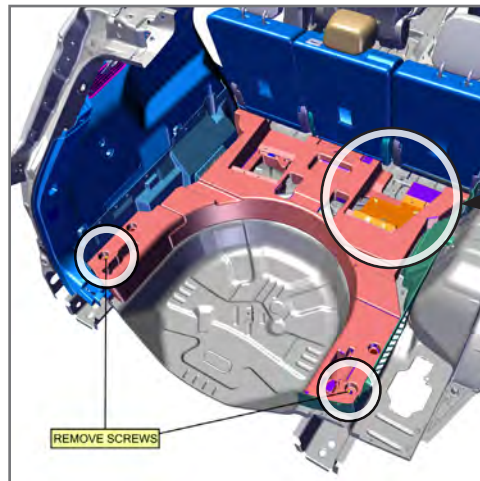

3. Remove the (2) 8 mm OEM bolts holding the end pieces in place.

4. Unclip the wire harness and remove the cover plate to remove the upper foam from the vehicle.

5. Remove OEM solid foam core from cargo area in 2 sections. Once the Bio-Seat System is installed, this will be reinstalled into vehicle.



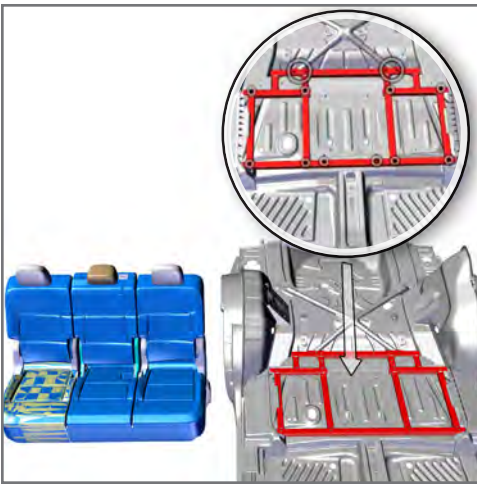

6. Remove the rear seat from the vehicle by disconnecting (3) wire harness connections located at each seat belt buckle. Remove the (10) OEM 13 mm bolts in front and (2) 15 mm nuts in the rear.
7. Remove buckles and wiring from each seat, then reconnect each belt into its respective harness. Place buckles in a bag and cable tie shut and secure to frame to prevent rattling.

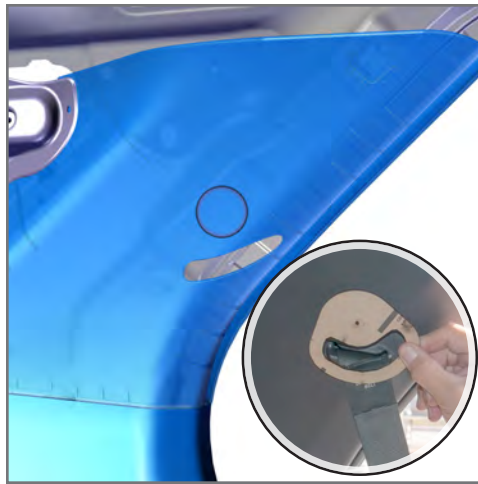

8. Place the provided Drill Template on the C-pillar trim around the seatbelt cutout. Place it so the DS is facing outward on the driver side and inward on the passenger side. Drill a 1-1/4" hole and remove the factory seat belt bolt.
9. Roll up the entire seatbelt and place inside the C-pillar trim.



10. Pre-assemble the Seat System Frame by attaching the Lower Seat Supports to the DS/PS legs using (4) 1/4" x 1/2" bolts.
11. "Loosely" attach the Top Bar Assembly to the DS/PS legs with provided (4)-3/8" x 3/4" bolts.

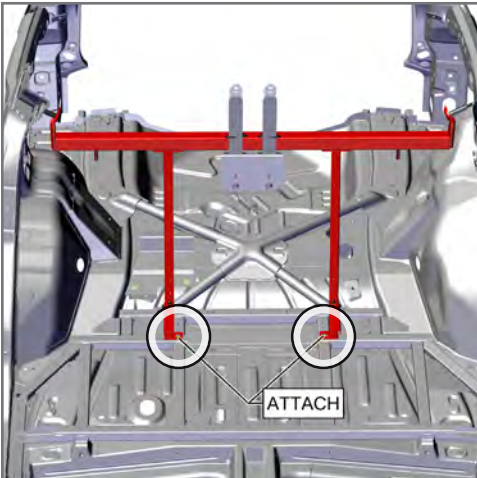

12. Insert the Frame Assembly into vehicle and lightly secure in place with previously removed OEM hardware.

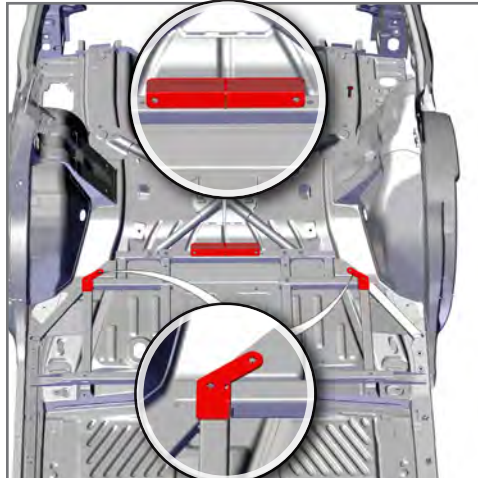

13. Attach the DS/PS Hip Side Tongue Brackets and Floor Bracket to the vehicles floor square tubing with previously removed OEM hardware.

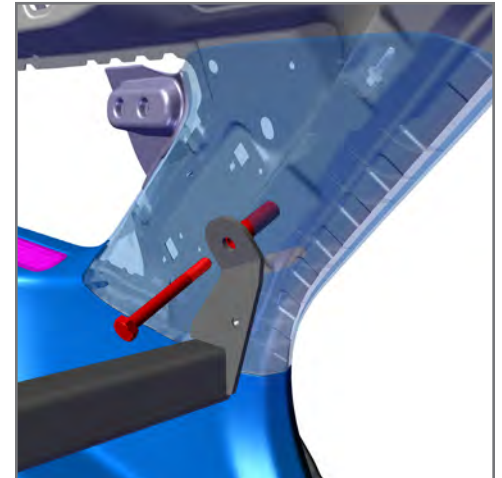

14. Tilt the Top Bar Assembly forward and insert the (2) 2.5" Spacers into the C-pillar trim securing with (2) 10 mm x 90 mm bolts.

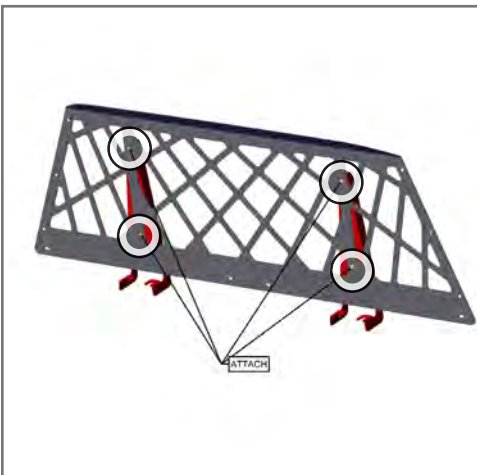

15. Attach the Cargo Barrier Brackets to the Cargo Barrier with provided (4) 1/4-20 Socket Head Cap Screws.



16. Align the slots of the Cargo Barrier Brackets to the "previously loosen" bolts of the Top Bar Assembly.
17. Fully secure all hardware at this time.



18. Secure the bottom of the Cargo Armor Brackets to the Top Bar with (2) #14 x 1" Tek Screw.

NOTE: SCREW LOCATIONS MARKED IN PICTURE.

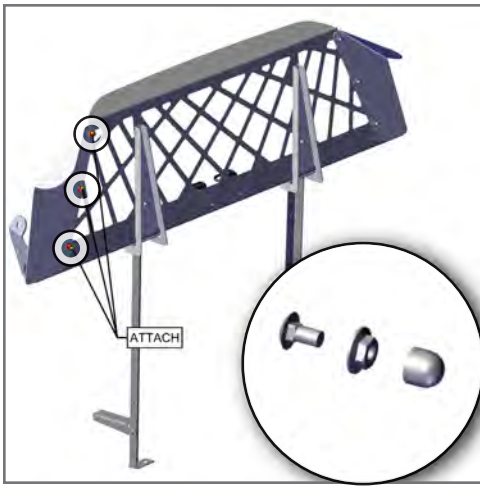

19. Secure the DS/PS Side Wings to the rear of the Cargo Armor with provided (6) 1/4-20 x 1/2 Carriage Bolts, 1/4-20 Flange Nuts and Nut Covers.



20. Attach the Seat Trim Seal on locations shown.

21. Place the seat into vehicle and position the seat flange onto Top Bar Assembly.



22. Secure the front face of the ABS Seat to the OEM seat frame structure with provided (4) #14 1 1/2" Tek Screws.

NOTE: FOR EASIER INSTALLATION MARK AND PRE-DRILL WITH A 1/8" DRILL BIT.



23. Place the Tooth C-Retainer on webbing on outboard seatbelt and outboard slot so that it pinches webbing and closes gap around webbing.

24. Secure with (4) #6 x .625 sheet metal screws on both sides.

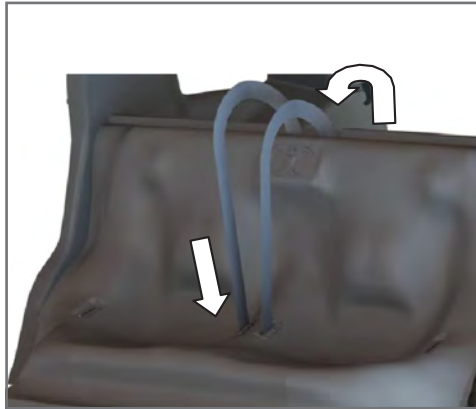

25. Attach the RED Ring Buckle to seatbelts.

26. Route the seat belts into the center slots of the ABS seat.



27. Install (2) Belt Slot Covers around retractor webbing using built in cutout in Belt Slot Covers.

28. Ensure belt installation cutouts in belt slot covers face each other and toward center of vehicle.

29. Using (14) #6 x .625 sheet metal screws secure Seat Slot Covers to seat.

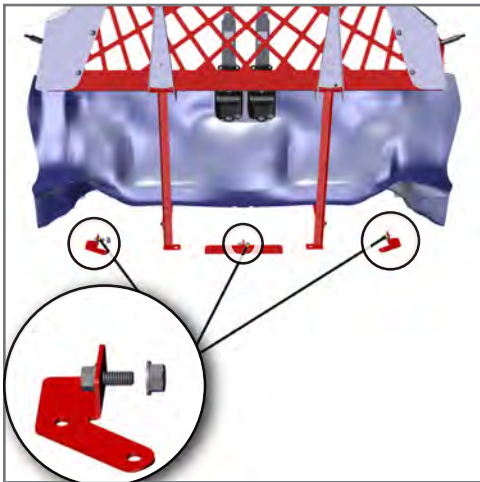

30. From the cargo compartment of the vehicle attach the retractable belt to the center anchor point located on the Floor Bracket and the outboard seat belt on the DS/PS Tongue Bracket.



31. Attach Storage Tongue to Seat Belt Buckle to best determine a mounting location for the (2) Storage Tongues.

NOTE: BE SURE TO INSTALL THE STORAGE TONGUES LOW ENOUGH IN THE VEHICLE TO AVOID HEAD INJURY DURING PRISONER ENTRY AND EXIT.



NOTE: TRIM CARGO COVER TO FIT AROUND CARGO BARRIER VERTICAL SUPPORTS. SEE DIAGRAM ON LAST PAGE.

32. Attach the DS/PS sides of the Cargo Cover together with the supplied Center Bracket using (4) 1/4" x 1/2" Button Head Cap Screws and Nylock Nut.

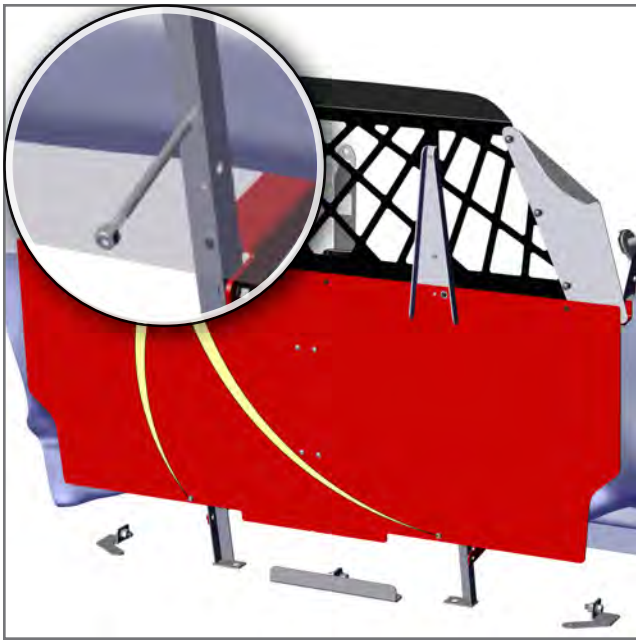

33. Attach the Cargo Cover to the Top Bar Assembly with (4) 1/4-20 Socket Head Cap Screws.
34. Assemble a 1/4 Nylock Nut to the end of a 1/4" x 5" Threaded Stud leaving approximately 1/4" of thread on one end.
35. Insert the 5" Threaded Stud through the bottom of the Cargo Cover attaching to the Pem Nuts in the upright legs.



36. Reverse steps (1-5) to return the cargo area to its original condition.

Please Note: if you have purchased the Poly Cover for Seat Replacement System (475-1571), it installs on the prisoner side of the Secure Grid Upper Barrier.

! CAUTION !

CHEMICAL CLEANERS will damage plastic seats and parts.
CLEAN ONLY with mild antibacterial soap and water.

If you have questions or need further assistance please call Technical Support: 1.877.455.6886



209 W. EASY ST., ROGERS, AR 72756 • JOTTOPUBLICSAFETY.COM • 5/24

Jotto Desk™ is a patented product and Registered Trademark of Assembled Products™ Corporation.
Specifications subject to change without notice.

050-0136-01



