



# REAR CARGO AREA WINDOW ARMOR

2020+ FORD PI UTILITY

Installation Instructions

475-1113

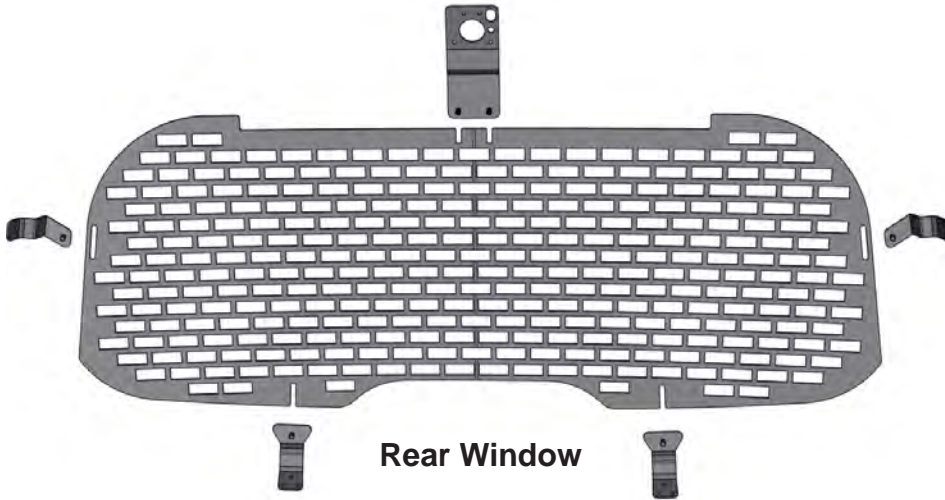

Driver Side

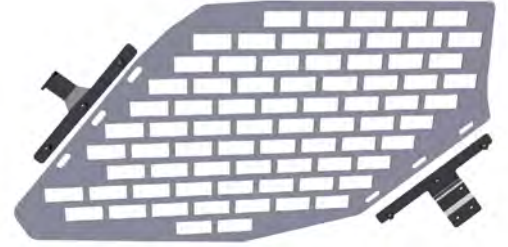

Passenger Side

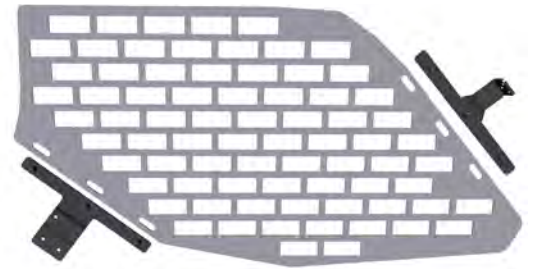

**WINDOW ARMOR MUST BE INSTALLED BEFORE CARGO BARRIER**

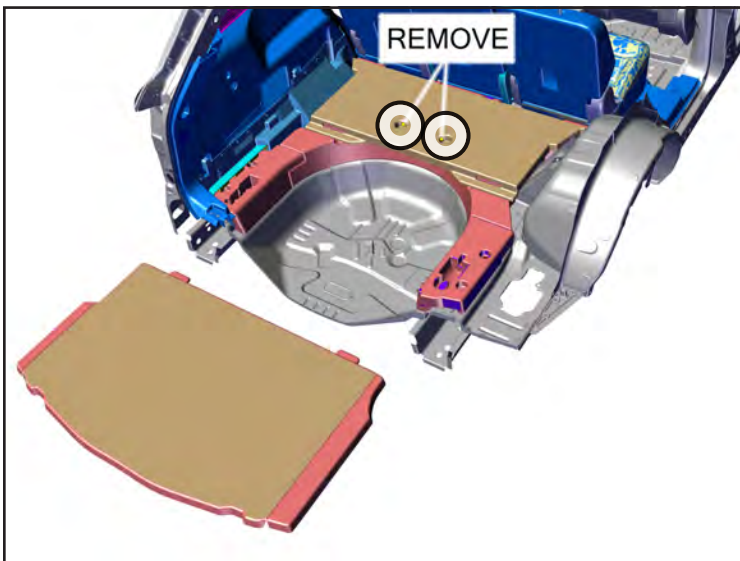

1. Remove OEM flooring starting at the hatch. This portion can simply be pulled out.
2. Remove the (2) bolts to remove forward flooring and set aside for replacement.

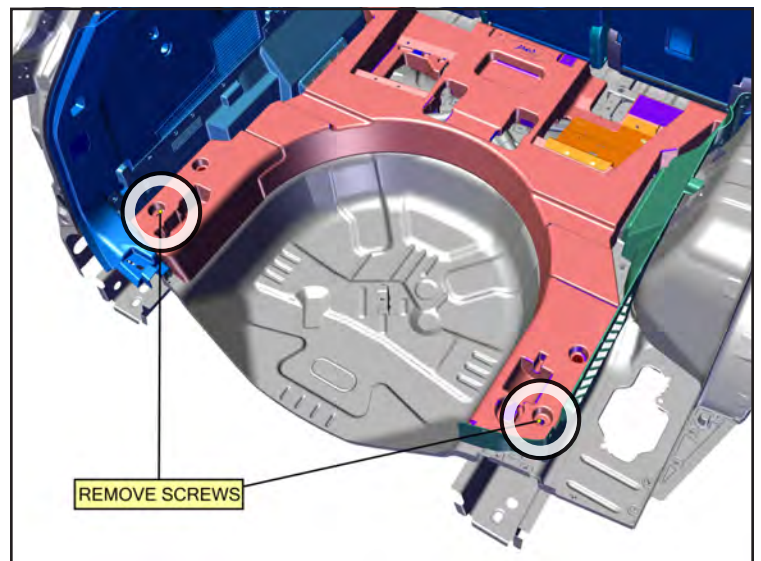

3. Remove the (2) 8 mm OEM bolts holding the end pieces in place.
4. Unclip the wire harness and remove the cover plate to remove the upper foam from the vehicle. Once Window Armor is installed, this will be reinstalled into vehicle.
5. Remove OEM solid foam core from cargo area in 2 sections.



6. With a trim removal tool pry, around the edges of the rear lower cargo trim to separate it from the cargo compartment.



7. Remove the LH/RH lower side panel by using a small flat head screwdriver to pop up the center of the press in plastic pins. (14 per side)



8. Unscrew the LH/RH accessory hatch cover pins with a pair of pliers.



9. Start at the rear to remove the P/S upper side panel with a trim removal tool. Pull out far enough to unplug the cargo light and 12V power supply.

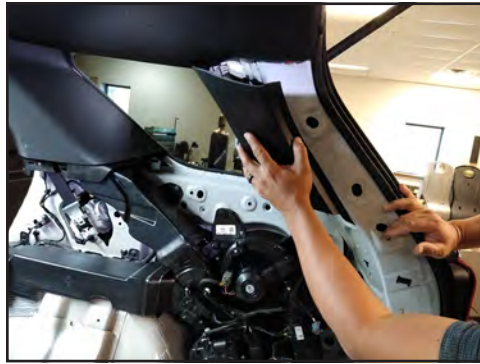

10. Pull the rear upper "D" pillar trim up and out to unclip from its location.



11. With a trim tool pop up the lower door trim panel. Remove the (2) press in pins holding the panel to the lower seat skirt fabric.



12. Remove the screw located on the bottom of the DS/PS "C" panel trim using an 8 mm socket.

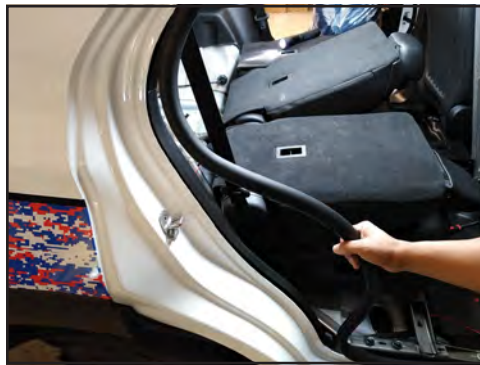

13. Pull the rubber door seal away from "C-pillar" and the upper side panel.

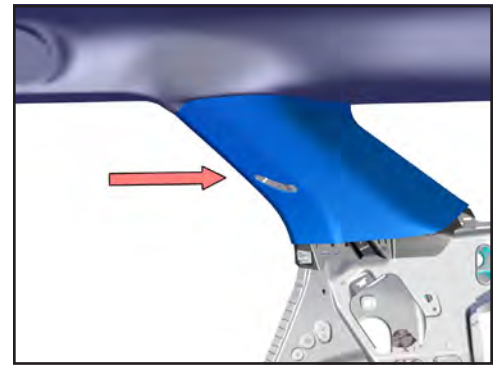

14. Use a trim removal tool to unclip and pull the "C" pillar" trim away from its location.

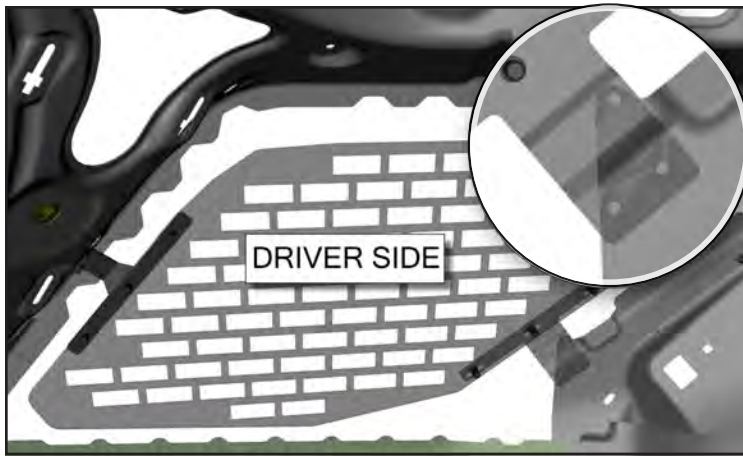

15. Loosely attach the brackets to the middle of the slots located in the Side Window Armor with provided flange nuts
16. Align the lower bracket closest to the "C" pillar to its mounting location "See Diagram" and secure with provided self-tapping screws. Once lower "C" pillar bracket is secure adjust the rear "D" pillar bracket within the slot to position. Secure with self-tapping screws and tighten flange nuts.

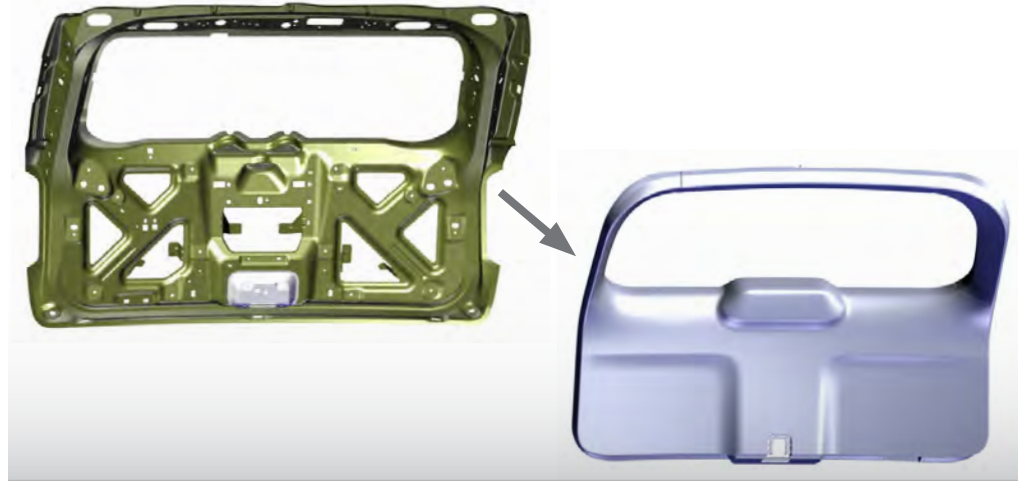
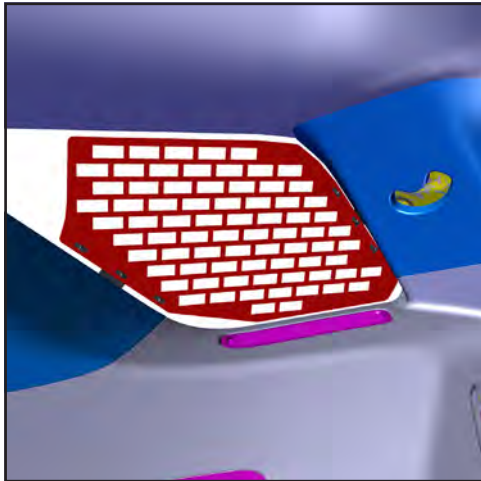

17. With the Window Armor attached, reinstall all previously removed side trim to complete assembly.
18. Remove the rear deck lid by locating the (2) screws located by the grab handle of the rear deck lid. With a trim removal tool, pry around the edges of the plastic trim to separate it from the rear deck lid.

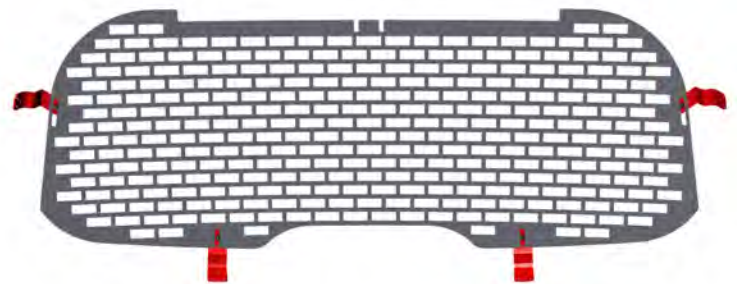
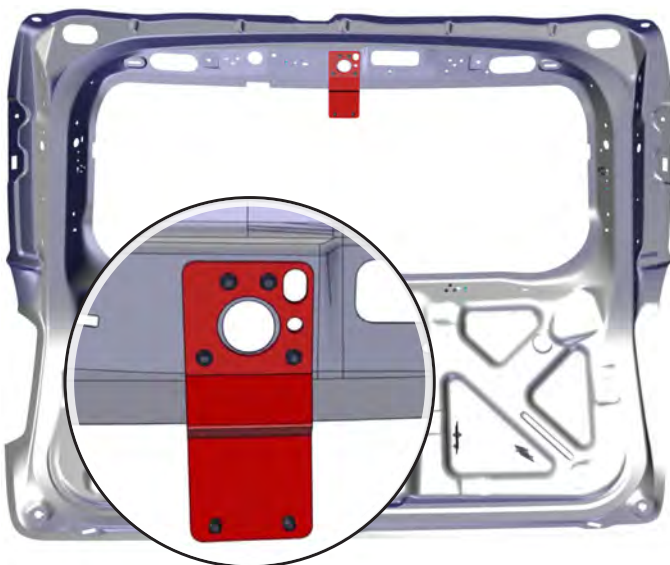

19. Attach the Top Center Bracket to the rear deck lid by aligning the circular profile, secure in place with self-tapping screws.
20. Lightly secure the remaining mounting brackets to the Rear Window Armor with provided 1/4"-20 flange nuts.

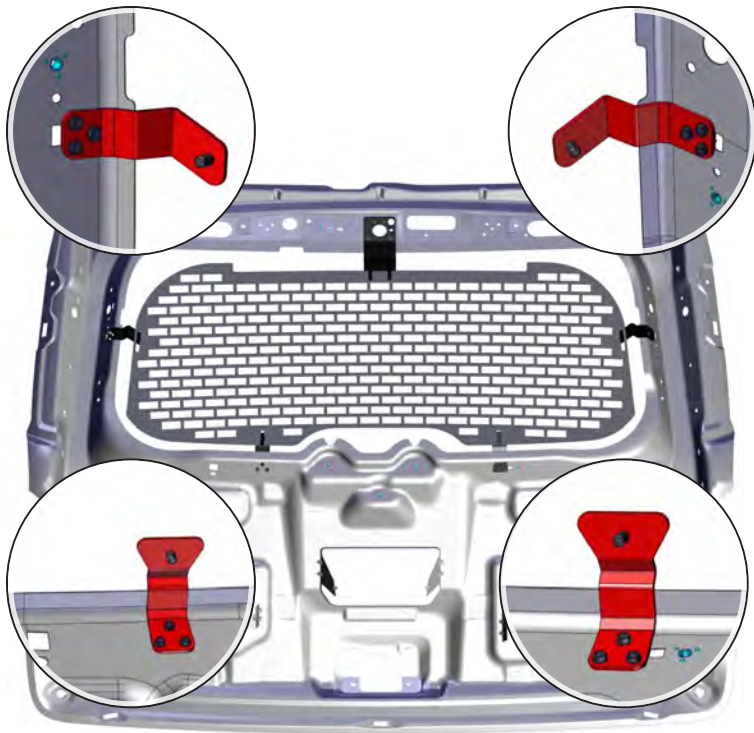

21. Secure the assembled Window Armor to the Top Center Bracket with provided ¼-20 flange nuts. Adjust to the desired location and ensure all brackets are mounted under all wires or connections. Mark the brackets mounting position and secure in place with provided self-tapping screws.

22. Reinstall the plastic trim to the rear deck lid ensuring all mounting points are clipped in and the previously removed (2) screws are secured. Attach the Rear Window Armor to the Window Armor Brackets with ¼-20 flange nuts . Adjust the Window Armor to the desired position and secure in place and finish by attaching the nut covers.

If you have questions or need further assistance please call Technical Support: 1.877.455.6886



209 W. EASY ST., ROGERS, AR 72756 • JOTTOPUBLICSAFETY.COM • 2/25

Jotto Desk™ is a patented product and Registered Trademark of Assembled Products™ Corporation.  
Specifications subject to change without notice.

050-0146-01

