



BAR STYLE WINDOW ARMOR

2019+ CHEVROLET SILVERADO

Installation Instructions

475-1404

475-1372

475-1407

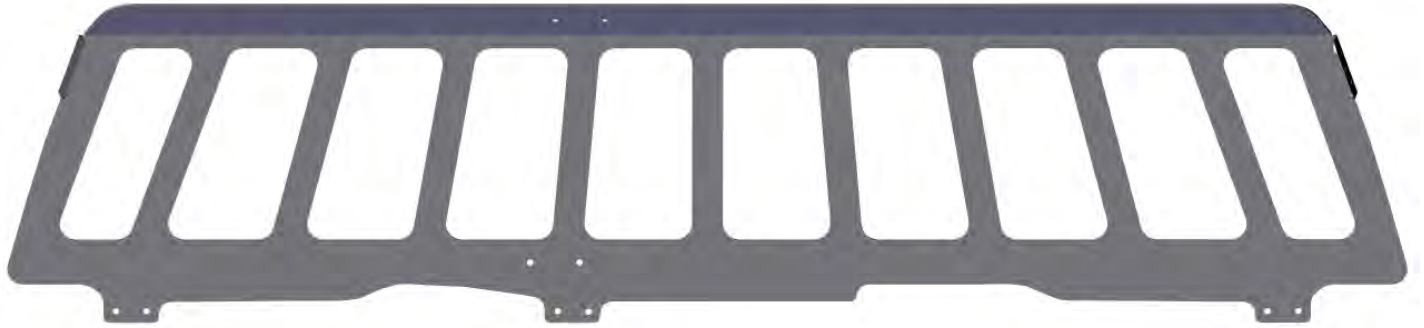

Rear Window Armor



D/S Side Mount Bracket



P/S Side Mount Bracket

Lower Mount Brackets



D/S Door Window Armor

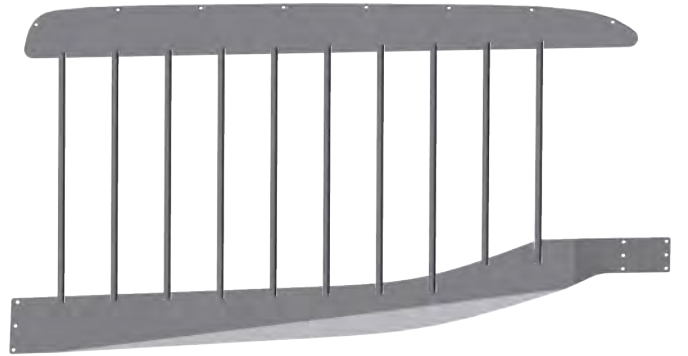

P/S Door Window Armor

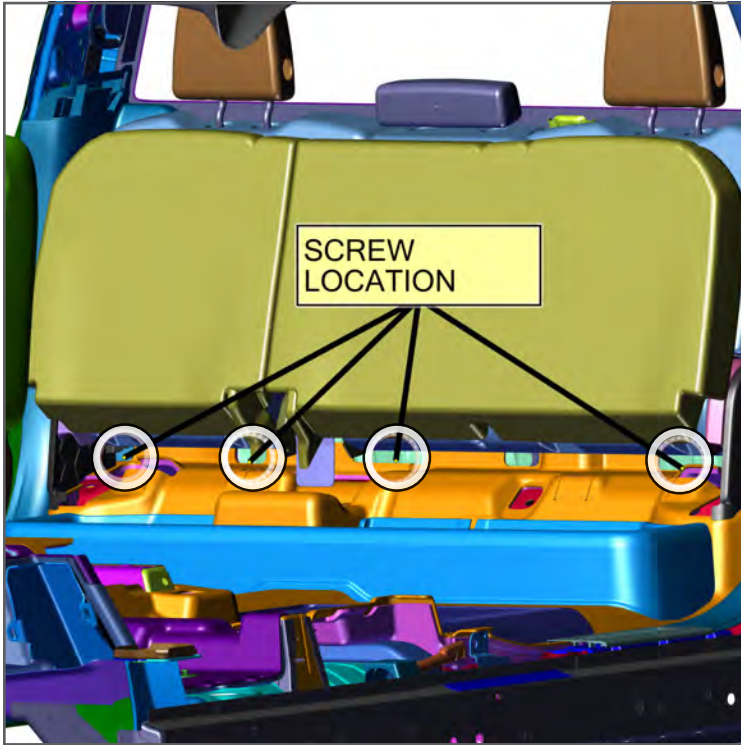

1. Lift lower rear seat cushions to access and remove (4) 10 mm bolts located on the lower section of the backseat rest. Fold seat back down.



2. Remove head rest and (6) plastic head rest socket with a flat head screwdriver securing the seat to the back of the vehicle.

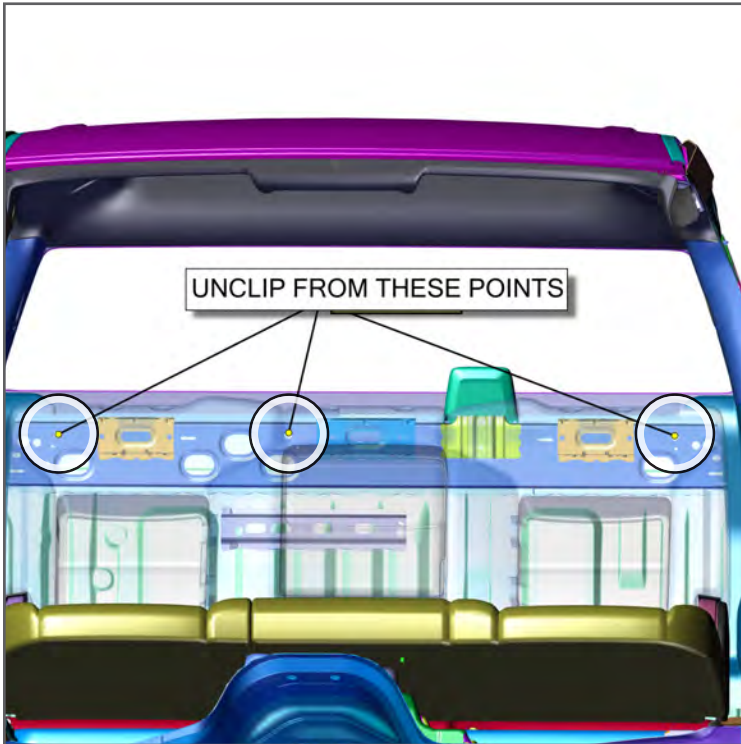

3. With a 90-degree angle pick, lift each locking tab located by the tie down straps on the rear seat. Once removed, shift entire rear seat forward.



- (Close up example of using the angle pick to lift the three locking tabs from previous step.)

Angle Pick



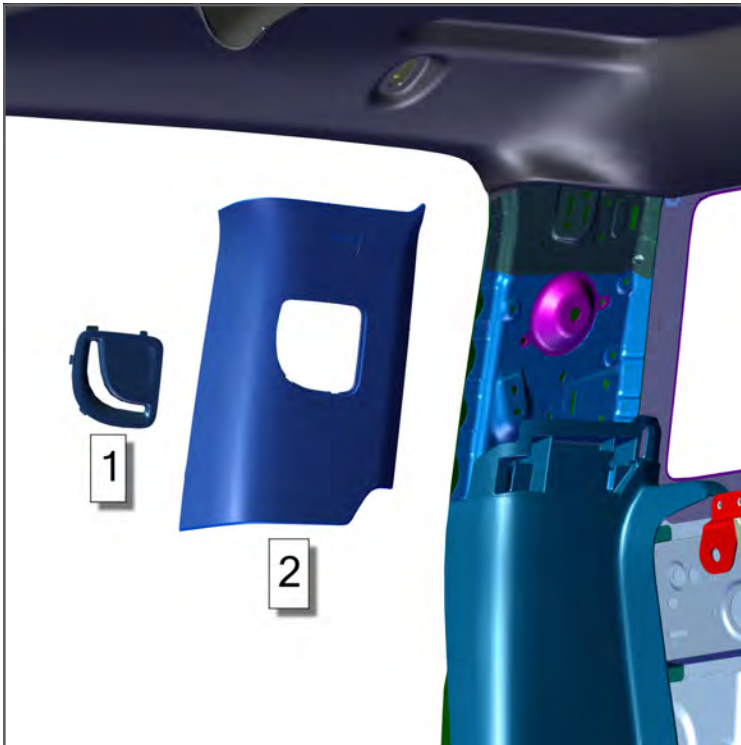

4. Remove "C" pillar upper OEM trim. With a flat trim tool, remove Seatbelt socket guide (1) then the trim (2).



5. Remove the 7 mm screw attaching trim to the vehicle via nylon strap.

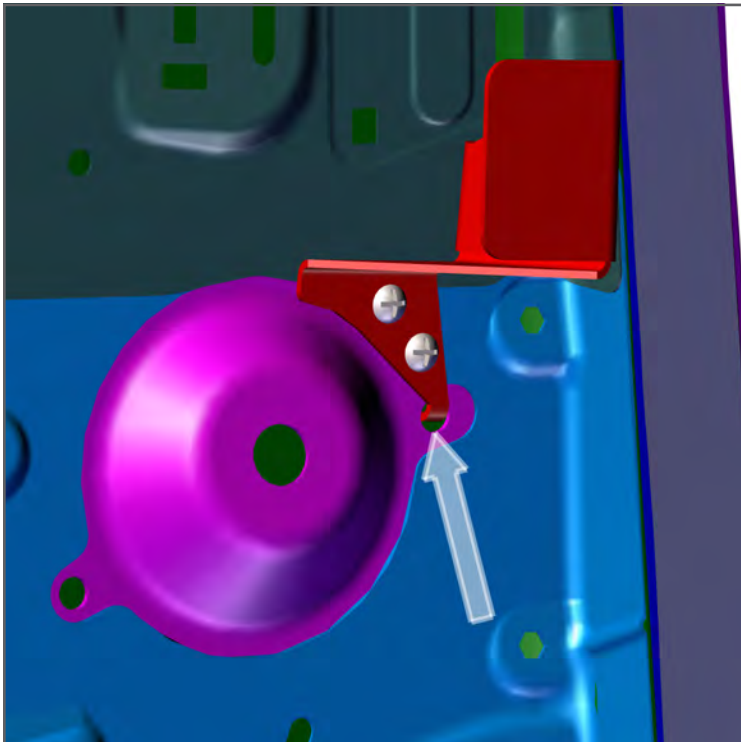

6. Attach the "P/S Armor Upper BKT" by inserting locating tab into place and secure with provide hardware.
REPEAT FOR OTHER SIDE.



7. Replace OEM "C" Pillar Trim on top of P/S Side Armor Upper Brackets.
REPEAT FOR OTHER SIDE.

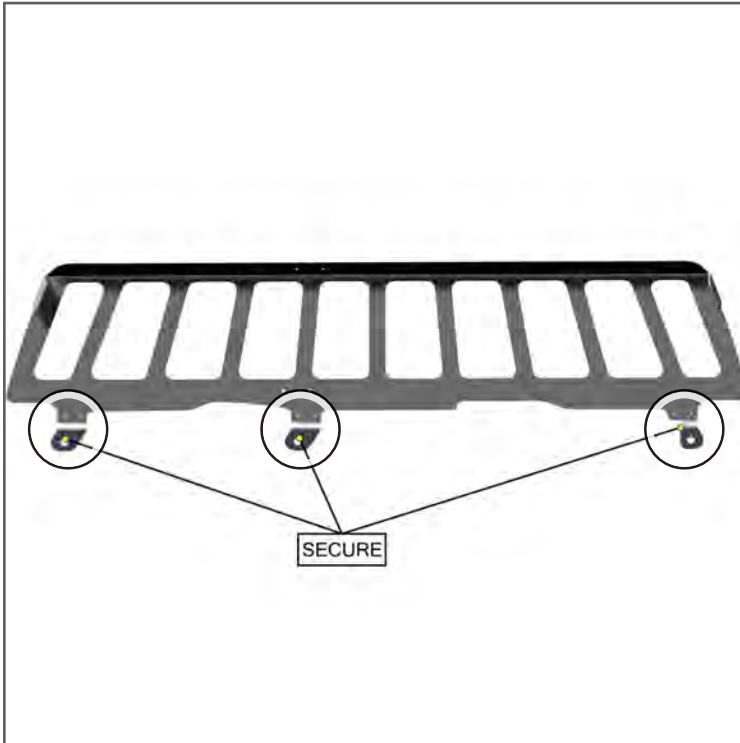

8. Loosely attach (2) P/S Lower Mount Brackets and (1) D/S Lower Mount Bracket to Rear Window Armor with provided (6) lock washers and button screws.



9. Remove (3) 18mm bolts attaching the tie down strap locations. Insert Window Armor with Brackets (behind the rear seat locking mechanism).



10. Pull the Window Armor forward away from the glass and secure to the DS/PS Side Mount Brackets with (6) self-tapping screws.



11. Once Window is in position, tighten all hardware.

REINSTALL REAR SEAT



12. Align P/S Door Window Armor into position following contour of door frame. Secure Window Armor into place using provided tek-screws.

If you have questions or need further assistance please call Technical Support: 1.877.455.6886



209 W. EASY ST., ROGERS, AR 72756 • JOTTOPUBLICSAFETY.COM • 2/25

Jotto Desk™ is a patented product and Registered Trademark of Assembled Products™ Corporation.
Specifications subject to change without notice.

050-0147-00

