

# GR4, ZRT - HATCH MOUNT GUN RACK

FORD PI UTILITY 2020+

## Installation Instructions

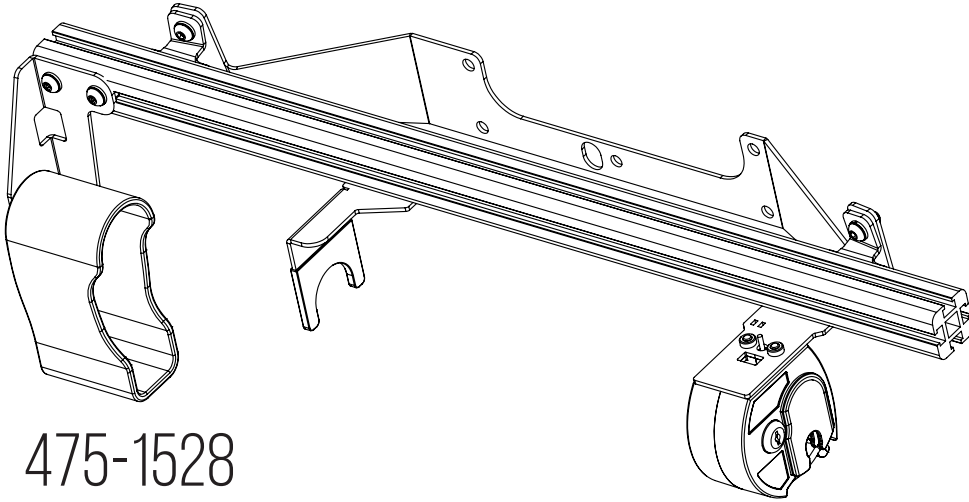

475-1528

GR4, ZRT, AR-BLM

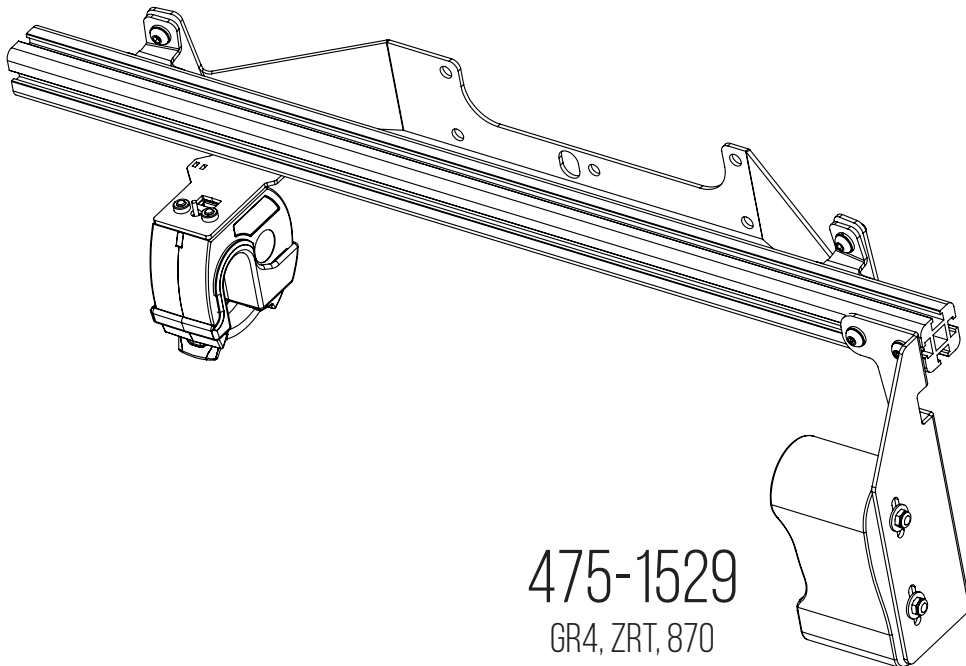

475-1529

GR4, ZRT, 870



1. Remove the Rear Deck Lid trim by locating and removing the (2) screws by the grab handle.
2. With a trim removal tool, pry around the edges of the plastic trim to separate it from the Rear Deck Lid.

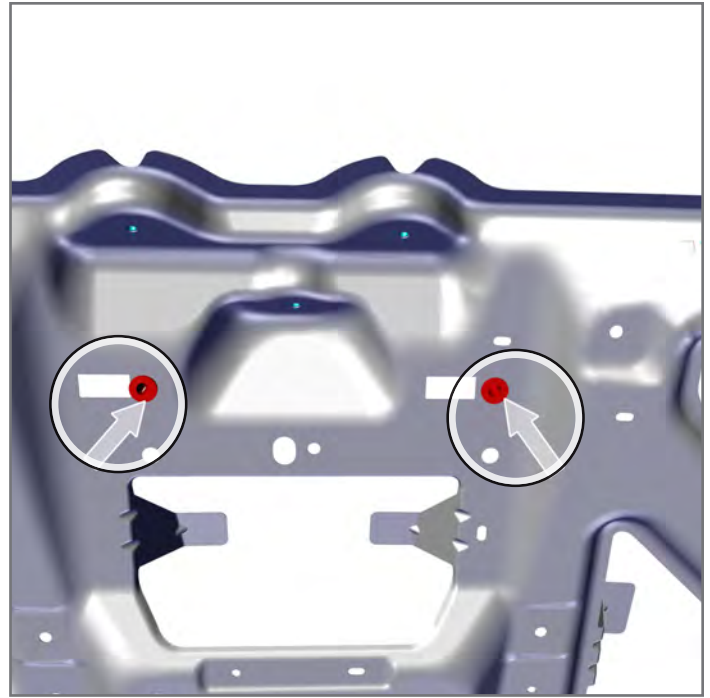

3. Locate the (2) factory holes on the Rear Deck Lid and install provided AVK Fasteners. Holes need enlarged to 1/2" diameter.

**FOLLOW THE PROVIDED AVK FASTENER INSTALLATION INSTRUCTIONS**

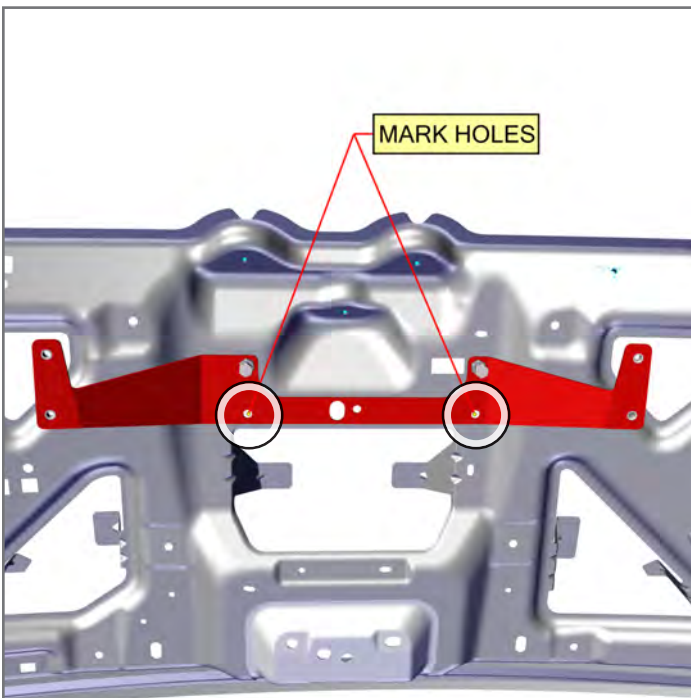

4. To drill out the lower holes, attach the GR4 Mounting Plate to the Rear Deck Lid via the previously installed top AVK Fasteners.
5. Mark the mounting hole locations on the bottom, remove the GR4 Mounting Plate.
6. Drill out lower holes to 1/2" diameter and install provided AVK fasteners.

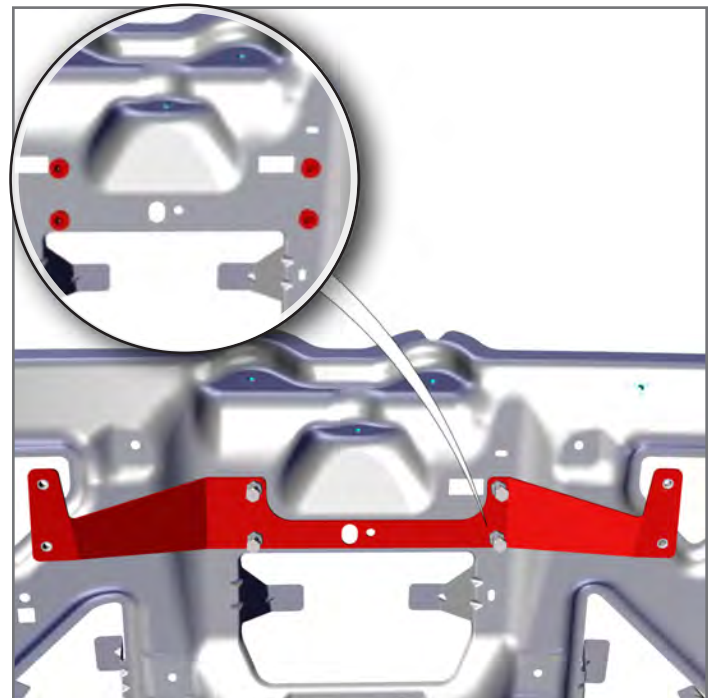

7. With AVK Fasteners installed, re-attach the GR4 Mounting Plate to the Rear Deck Lid with provided 3/16-18 x 1" bolts and secure.

**DO NOT USE THE 1 1/2" BOLTS PROVIDED TO SECURE THE AVK FASTENERS OR DAMAGE MAY OCCUR TO VEHICLE!**

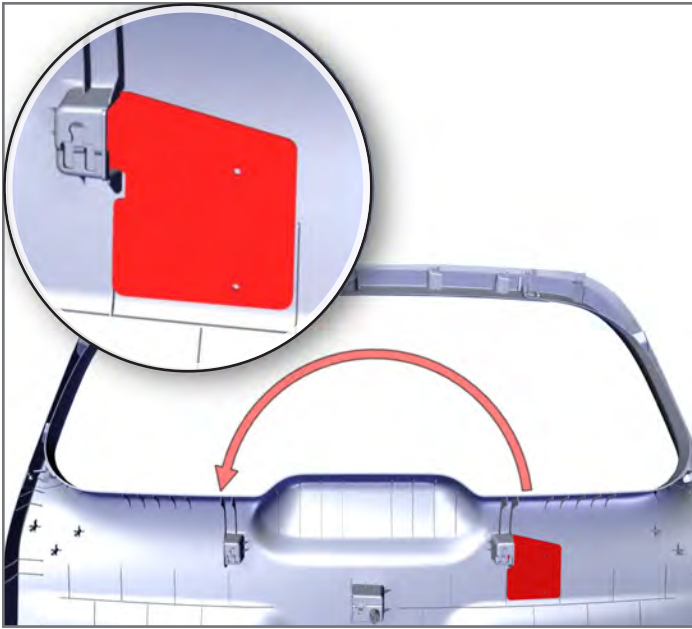

8. Use the universal drill template to drill out the DS/PS GR4 mounting points on the trim. The tab on the drill template will locate itself in the protrusion of the plastic trim.
9. Drill a  $\frac{1}{16}$ " pilot hole then a  $\frac{1}{2}$ " hole.

10. Reinstall the plastic trim to the Rear Deck Lid ensuring all mounting points are clipped in and previously removed (2) screws are tight.
11. Secure the GR4 Gun Rack to the GR4 Mounting Plate with provided lock washers and socket button head cap screws with a  $\frac{3}{8}$ " hex bit socket.

## AVK Fastener Installation Instructions

AVK Installation video can be viewed at:

<http://jottopublicsafety.gojotto.com/additional-categories/downloads.html>

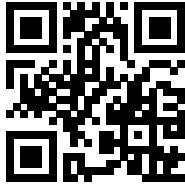

1. Drill out existing hole to  $\frac{1}{2}$ " or drill new hole per installation instructions.



2. Place  $\frac{5}{16}$ -18 x  $1\frac{1}{2}$ " long bolt through the  $\frac{3}{8}$ " flange nut and hand thread bolt into the AVK Fastener.



3. Place into  $\frac{1}{2}$ " drilled hole.



4. Use  $\frac{9}{16}$ " box end wrench to secure the flange nut.



5. Apply pressure on the flange nut, pressing AVK Fastener into hole.
6. Using an air wrench, tighten the  $\frac{5}{16}$ -18 x  $1\frac{1}{2}$ " bolt.



7. This will allow the AVK Fastener to secure onto the backside of the metal.
8. Remove  $\frac{5}{16}$ -18 x  $1\frac{1}{2}$ " bolt.

**DO NOT REUSE BOLT FOR PRODUCT INSTALLATION**

If you have questions or need further assistance please call Technical Support: 1.877.455.6886



209 W. EASY ST., ROGERS, AR 72756 • [www.JottoPublicSafety.com](http://www.JottoPublicSafety.com) • 5/21

Jotto Desk® is a patented product and Registered Trademark of Assembled Products™ Corporation.  
Specifications subject to change without notice.