



REPLACEMENT BIO-SEAT SYSTEM

2021+ CHEVY TAHOE

Installation Instructions

475-1743

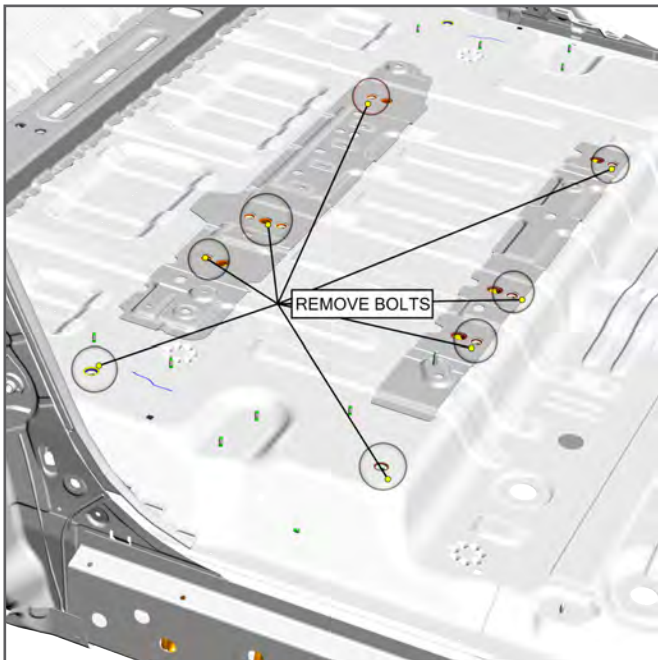

1. Remove (9) OEM bolts securing second row seat and remove seat assembly. Keep hardware for later use.

2. Remove the upper C-Pillar trim by popping out square trim cover, giving access to the 9/32" screw at the top of the headliner.

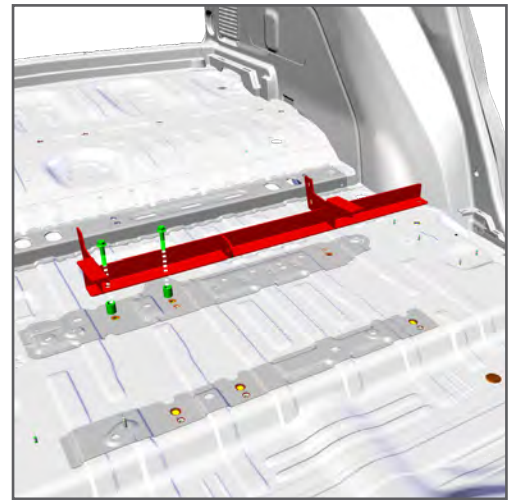
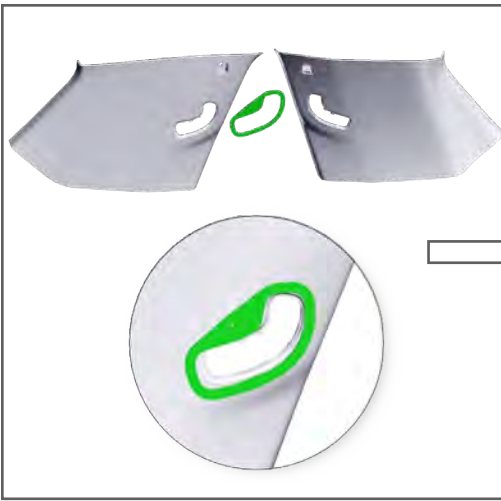

3. Using provided drill template (P21T60DT), drill 1/8" pilot hole into C-Pillar trims, follow up with 1-1/4" hole saw to cut out plastic trim. Remove upper C-pillar seat belt bolt and replace with Seatbelt Standoff Bolt. Roll up seat belts and secure with zip ties and reinstall C-Pillar trim.

4. Loosely install Lower Support Bracket using provided (2) M10 x 50mm bolts and (2) spacers.

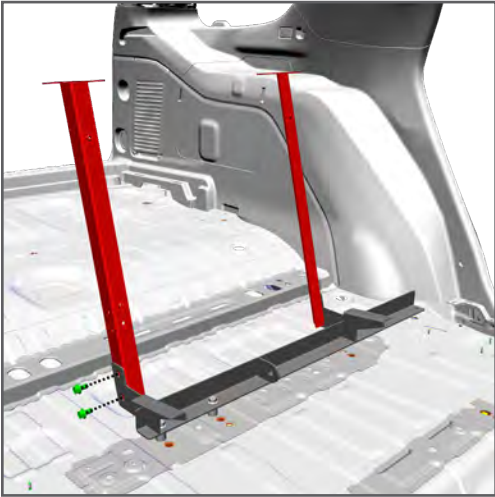

5. Install DS/PS Vertical Support Legs using provided (4) 3/8"-16 x 5/8" bolts.

6. Install Top Bar Frame through the DS/PS seatbelt slots using provided (2) 7/16 x 1" hex head bolt and (2) external tooth lock washer.

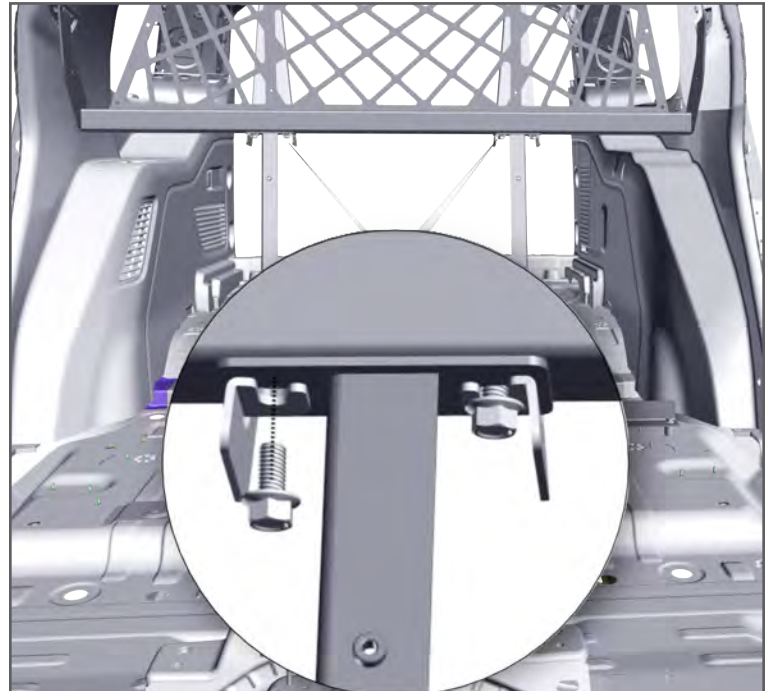
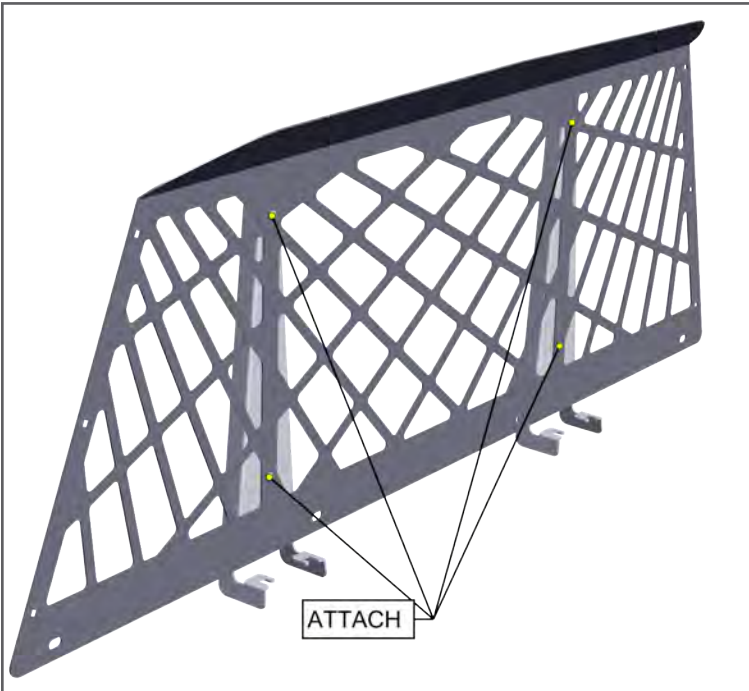

7. Attach the Support Grid Brackets to the Secure Grid with (4) 1/4-20 x 1/2" button head cap screws.

8. Attach the Secure Grid assembly to the Top Bar Frame and Vertical Support Legs with provided (4) 3/8 x 3/4 hex head bolt.

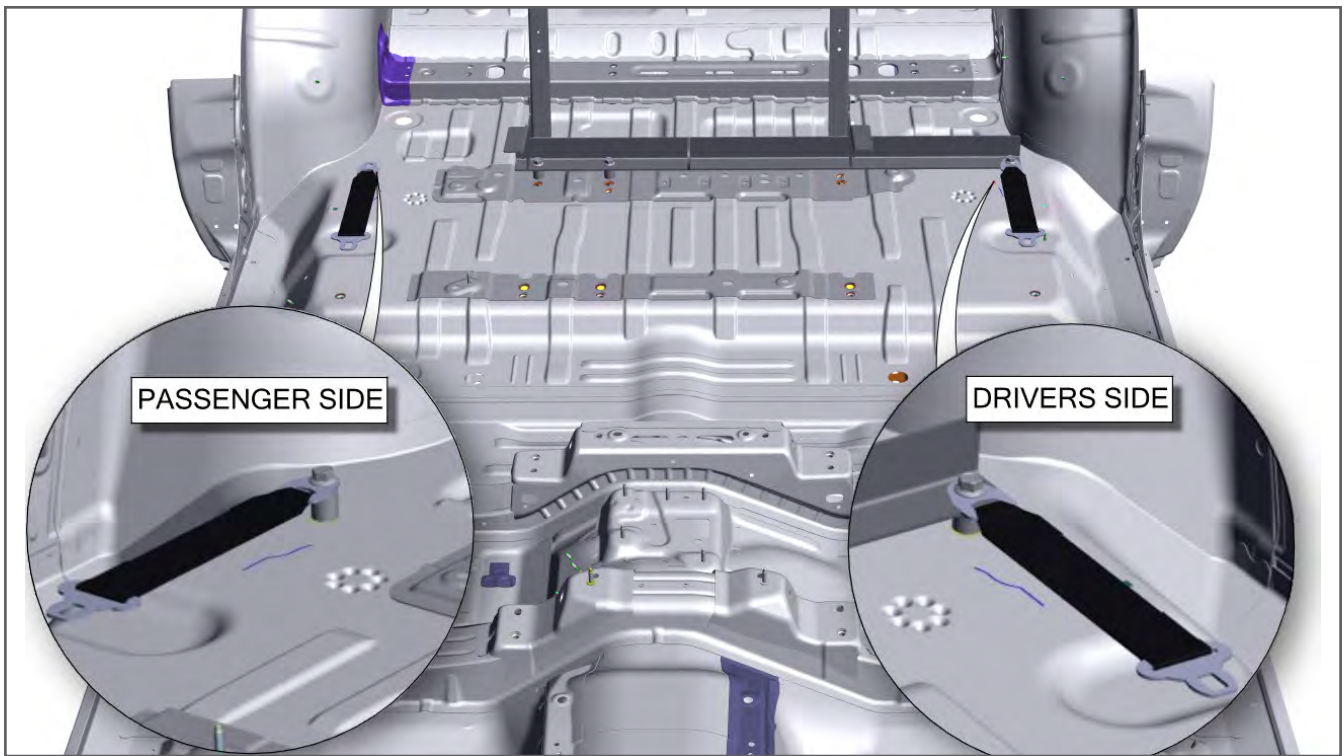

9. Attach the Hip Side Tongue Belts with provided (2) M10 x 50 mm bolts and (2)-spacers. Driver side will be on top of the Lower Vertical Support Bracket and passenger belt will be located at the rear outer most passenger seat bolt location.

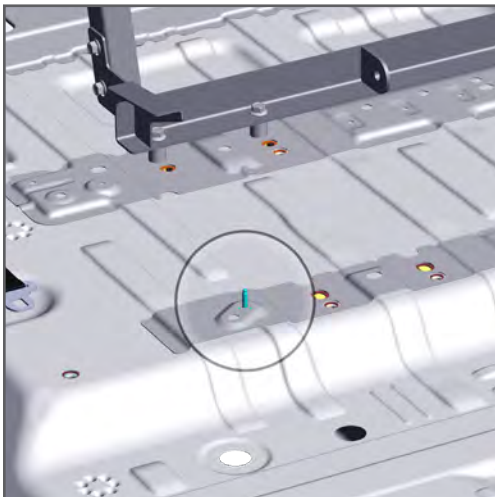

10. Remove the plastic alignment stud on the passenger side floor.

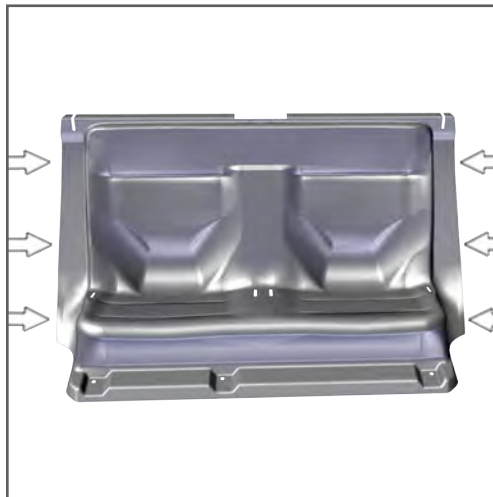

11. Before setting ABS Seat into position, attach the Seat Edge Trim to the DS/PS edges.



12. Pull the Hip Side Tongues Belts through both driver and passenger side slots of the ABS Seat.

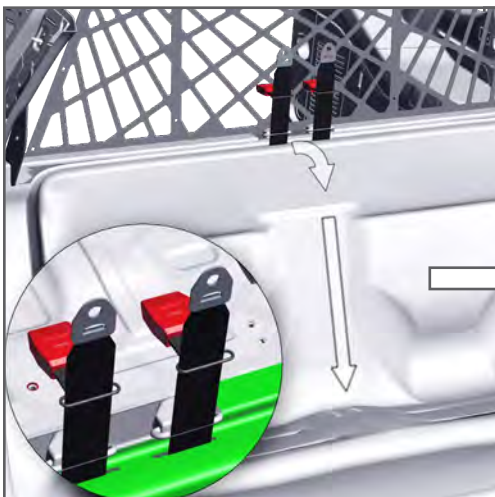

13. Pull the ends of the Seat Belt Retractor through the top slots of the ABS Seat and put the ends of the Seat Belt Retractor through the Seat Belt Sliding Buckles. Pull the Retractor Belts through the middle of the ABS Seat slots and secure to the tab of the Lower Support Bracket with provided 7/16-20 x 1" flanged hex bolt and 1/16 hex nut.

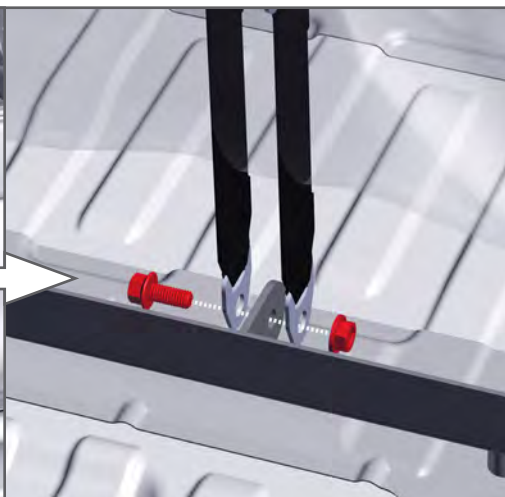

14. Secure the front of the ABS Seat with previously retained OEM seat hardware.

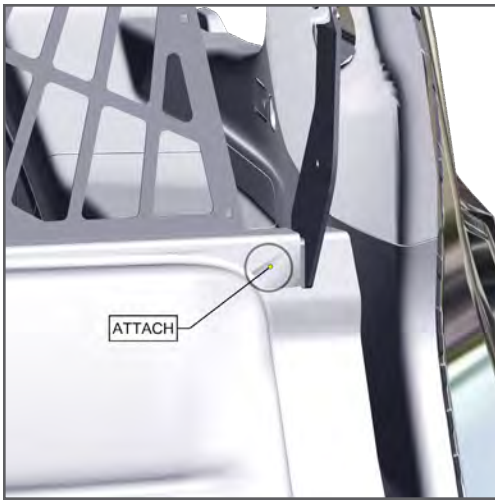

15. Use (2) #14 x 1 1/2" self-tapping screw to attach the top of the ABS Seat to Top Bar Frame.

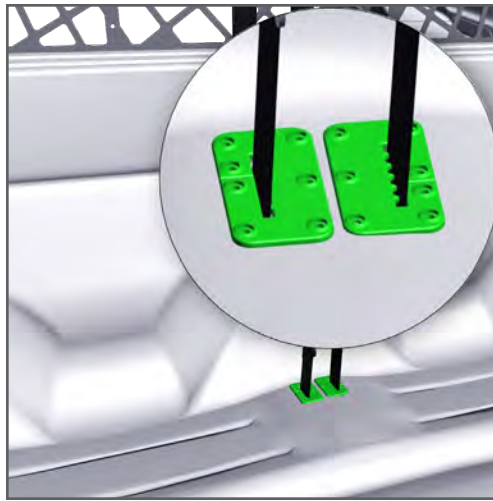

16. Place the center Seat Belt Covers around the previously installed seat belts. Align the Seat Belt Covers to the slots in the ABS Seat, attach with provided (14) #6 x 5/8 sheet metal screws.

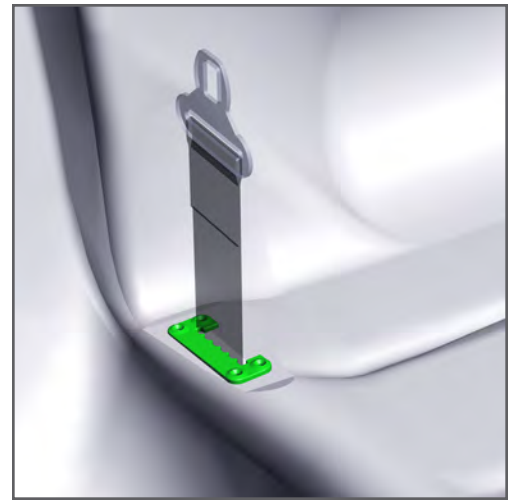

17. Attach the Toothed C-Retainer around DS/PS seat belt and secure to the ABS Seat with (8) #6 x 5/8 sheet metal screws.



18. Thread (2) 1/4-20 x 5" all thread into the top hole and secure in place with a 1/4-20 nut from the back side.



19. Outside of the vehicle, attach ABS Cargo Cover together to the center support with (6) 1/4-20 x 3/4" socket head cap screws and 1/4" nuts.



20. Place the assembled ABS Cargo Cover into the vehicle. Adjust the threaded studs as needed to give proper clearance when attaching the Cargo Cover. Secure the Cargo Cover to the Top Bar Frame with provided (2) #14 x 1" tek-screws and (4) 1/4-20 x 1/2" flanged hex head cap screws.

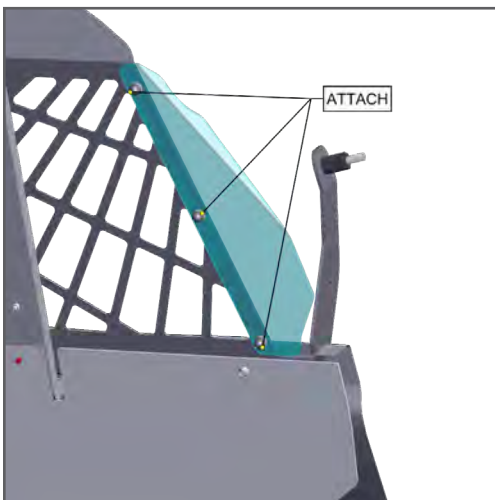

21. Attach the DS/PS Side Poly Wings from prisoner side with (6) 1/4-20 carriage bolts, 1/4" flange nuts and nut cover.



22. Attach the DS/PS Wing Covers to the Top Bar Frame with provided (2) 1/4-20 x 3/4" button head cap screws.

⚠ CAUTION ⚠

CHEMICAL CLEANERS will damage plastic seats and parts. **CLEAN ONLY** with mild antibacterial soap and water.

Please Note: if you have purchased the Poly Cover for Seat Replacement System (475-1599), it installs on the prisoner side of the Secure Grid Upper Barrier.



If you have questions or need further assistance please call Technical Support: 1.877.455.6886



209 W. EASY ST., ROGERS, AR 72756 • JOTTOPUBLICSAFETY.COM • 9/24

Jotto Desk™ is a patented product and Registered Trademark of Assembled Products™ Corporation.
Specifications subject to change without notice.



! CAUTION !

CHEMICAL CLEANERS will damage plastic seats and parts.
CLEAN ONLY with mild antibacterial soap and water.

BACK PANEL TEMPLATE