



SINGLE CELL LITE

2021+ DODGE DURANGO

Installation Instructions

475-1765

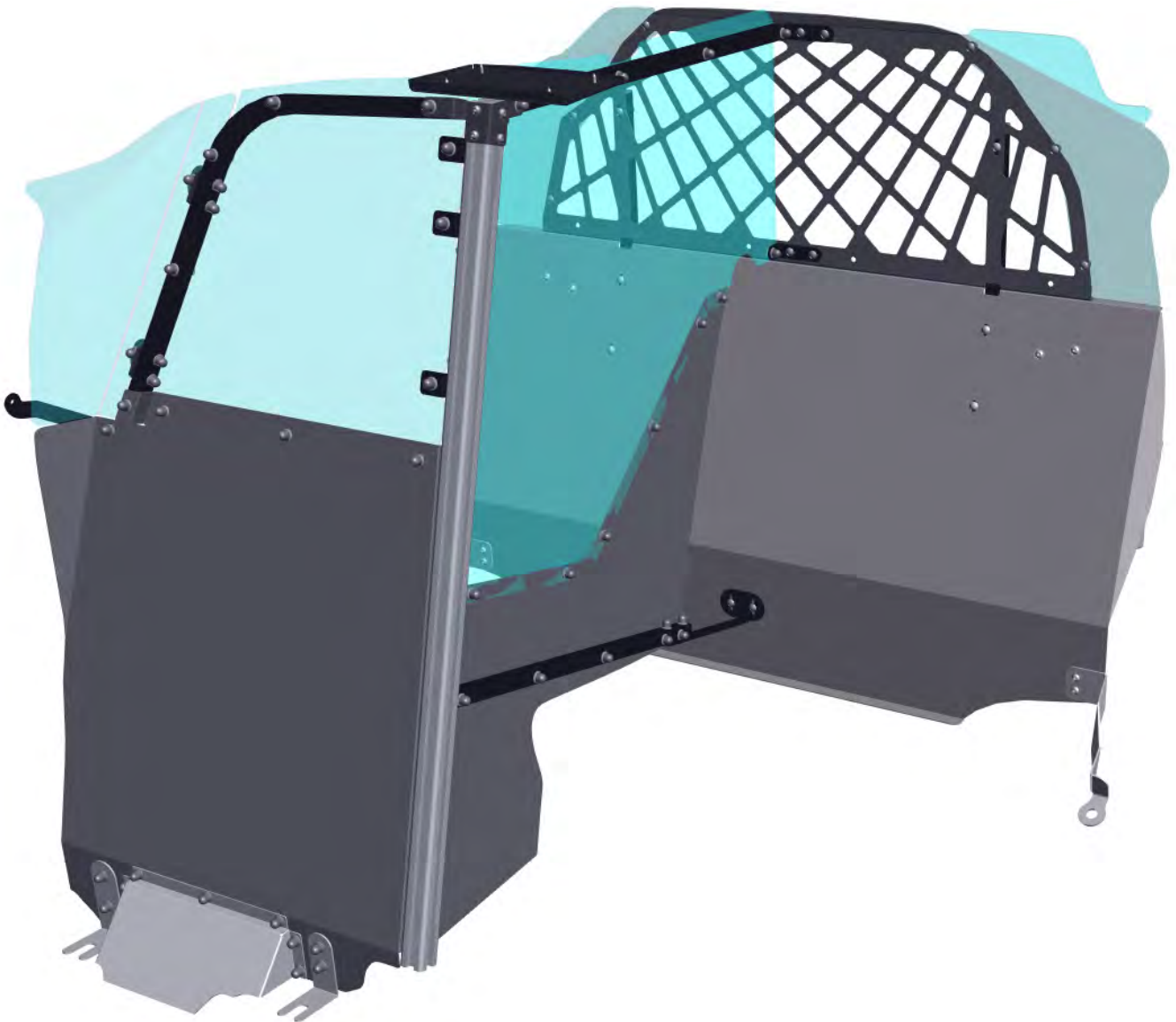

SINGLE CELL LITE



Headliner HVAC Cover



Upper Poly Wing



B-Pillar Bracket

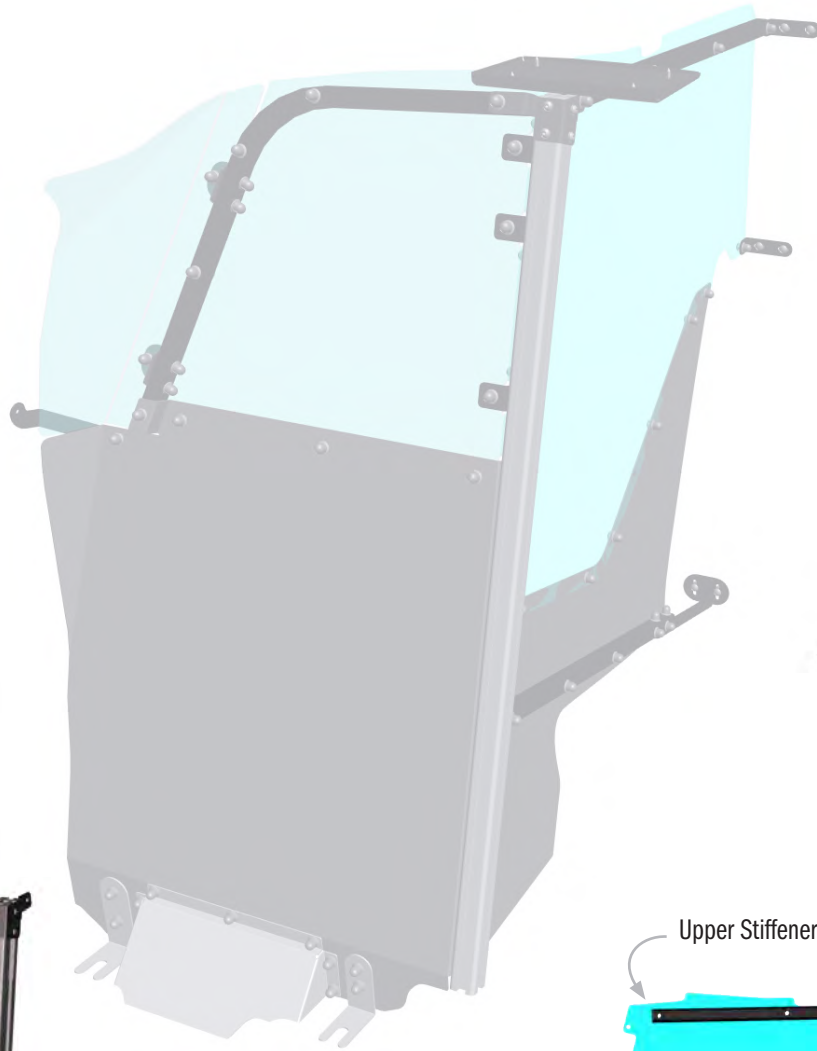

Secure Grid
Center Divider Brackets



Lower Steel
Center Divider Bracket



Assembled Front Divider



HSEP



Foot Mount Brackets

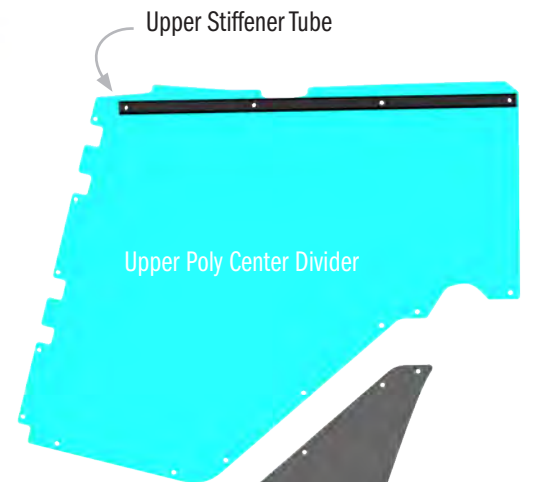

Upper Stiffener Tube

Upper Poly Center Divider

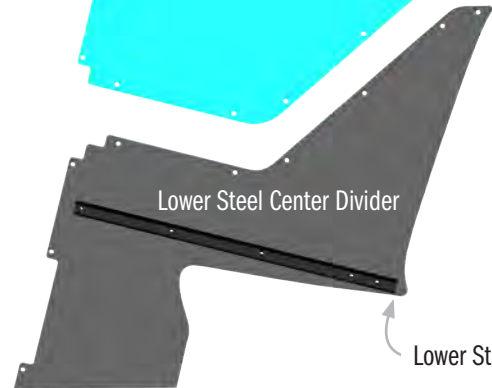

Lower Steel Center Divider

Lower Stiffener Tube

Before beginning the installation, confirm that you have received all of the parts for your package.
Read the instructions completely before starting installation.

Note: Install CB4 first



1. Pop plastic clips and remove Lower B Pillar Trim exposing $\frac{1}{2}$ " screw. Remove screw, then pop loose Upper B Pillar Trim from B Pillar.



2. Use 10 mm socket to remove OEM bolts and grab handle.

Note: Grab handle not reused.

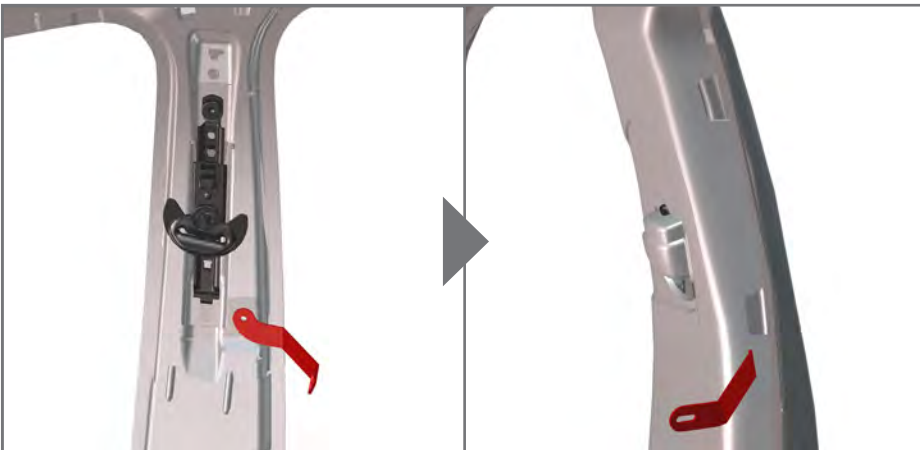

3. Attach the P/S B-Pillar Bracket with previously removed lower 10 mm bolt. Replace upper B-Pillar Trim and secure with previously removed $\frac{1}{2}$ " screw. Finish by snapping back into place the Lower B-Pillar Trim.

Note: Slight trimming around B-Pillar Bracket will be required.



4. Move seats completely forward and loosen the rear OEM 18 mm seat bolts.



5. Push seat up slightly to slide the Foot Mount Brackets under seat rails, between rail and rubber mat.

Note: Leave bolts loose currently.



6. Remove and disconnect rear controls from headliner if vehicle has them.



7. Detach the Rear AC Control Box from component housing. Then reconnect and position back into place.



8. Install Headliner HVAC Cover using the provided (4) black pan head screws.



9. Install Assembled Front Divider into vehicle. This will require a little twisting to get into proper position. Bolt down Foot Mount Brackets to Assembled Front Divider with provided carriage bolts and flange nuts.



10. Loosely attach B Pillar Bracket onto Assembled Front Divider. Use provided carriage bolt and flange nut.

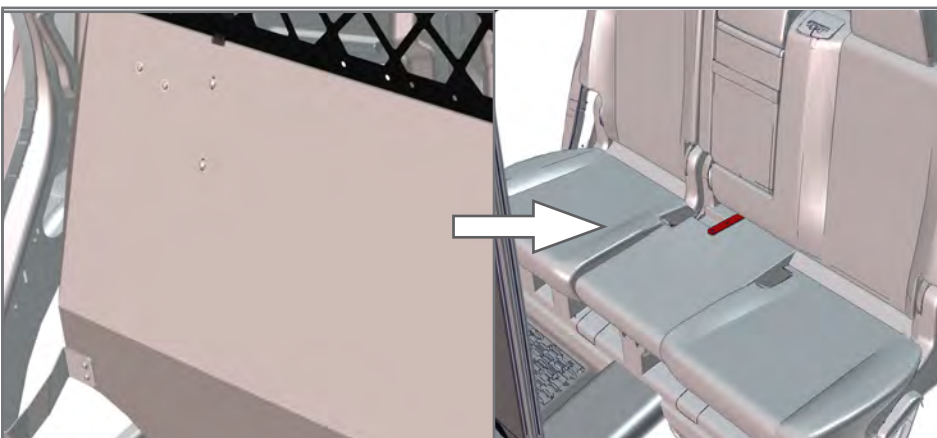

11. Fold down the D/S rear seat and secure the Lower Steel Center Divider Bracket to the Cargo Barrier Lower Steel Panel with provided carriage bolts and flange nuts.

NOTE: Bracket protrudes between the seat cushions.

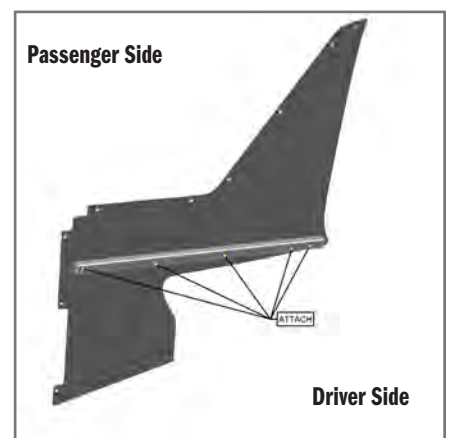

12. Outside of vehicle, attach the Lower Stiffener Tube to the D/S Upper Poly Center Divider with provided carriage bolts and flange nuts.

13. Install the now assembled Lower Steel Center



Divider on top of the rear seat and attach the end of the Lower Stiffener Tube to the Lower Steel Center Divider Bracket with provided carriage bolts and flange nuts.

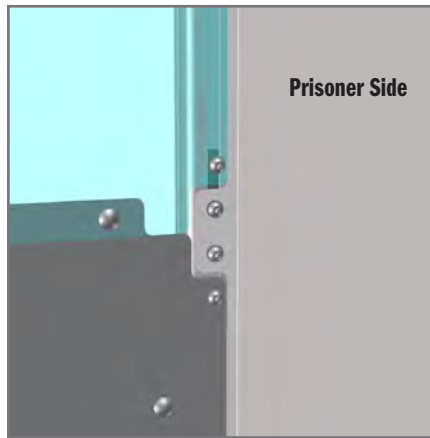

14. Loosely secure Lower Steel Center Divider onto Assembled Front Divider to the pre-positioned T-Blocks located in the rail of the Extruded Backbone with provided socket head cap screws.

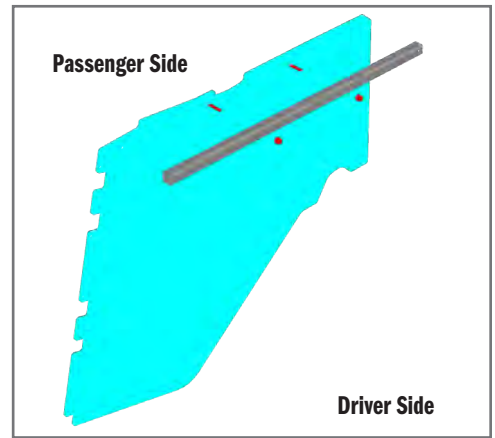

15. Outside of vehicle, attach the Stiffener Tube to the D/S Upper Poly Center Divider with provided carriage bolts and flange nuts.



16. Attach Upper Poly Center Divider to Lower Steel Center Divider and Assembled Front Divider from P/S using provided carriage bolts and flange nuts.
Note: Loosely tighten all bolts at this time.

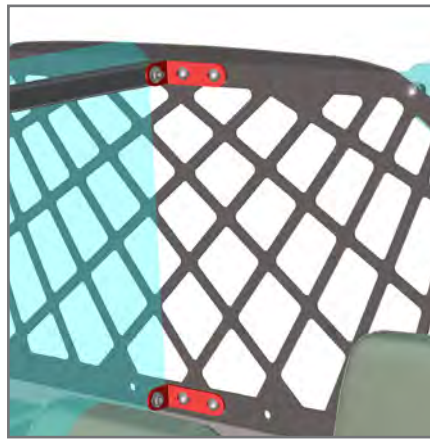

17. Attach the Secure Grid Center Divider Brackets to the Secure Grid, Stiffener Tube, and Upper Poly Center Divider with provided carriage bolts and flange nuts.

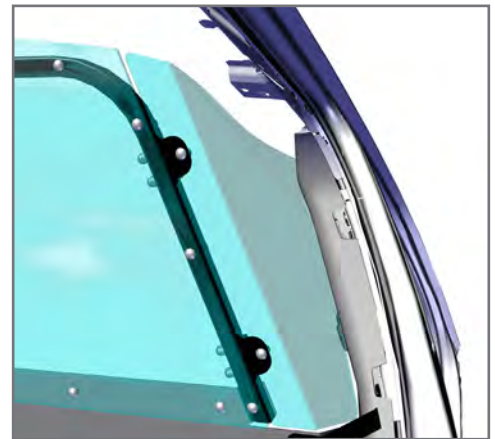

18. Install Upper Poly Wing from officer side and secure with provided carriage bolts and flange nuts.

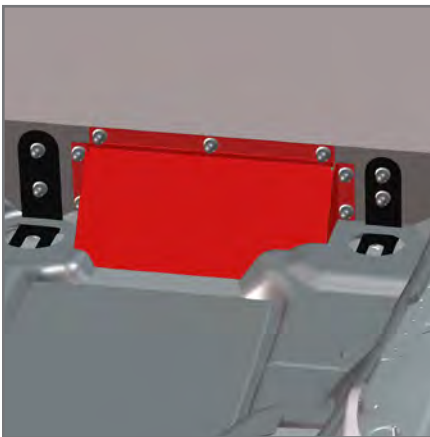

19. Secure the HSEP to the front of the Assembled Front Divider with provided carriage bolts and flange nuts.
Note: Install cap nut covers on all flange nuts.

If you have questions or need further assistance please call
Technical Support: 1.877.455.6886

