



SINGLE CELL LITE

2021+ FORD F-150 SSV/POLICE RESPONDER

Installation Instructions

475-1812

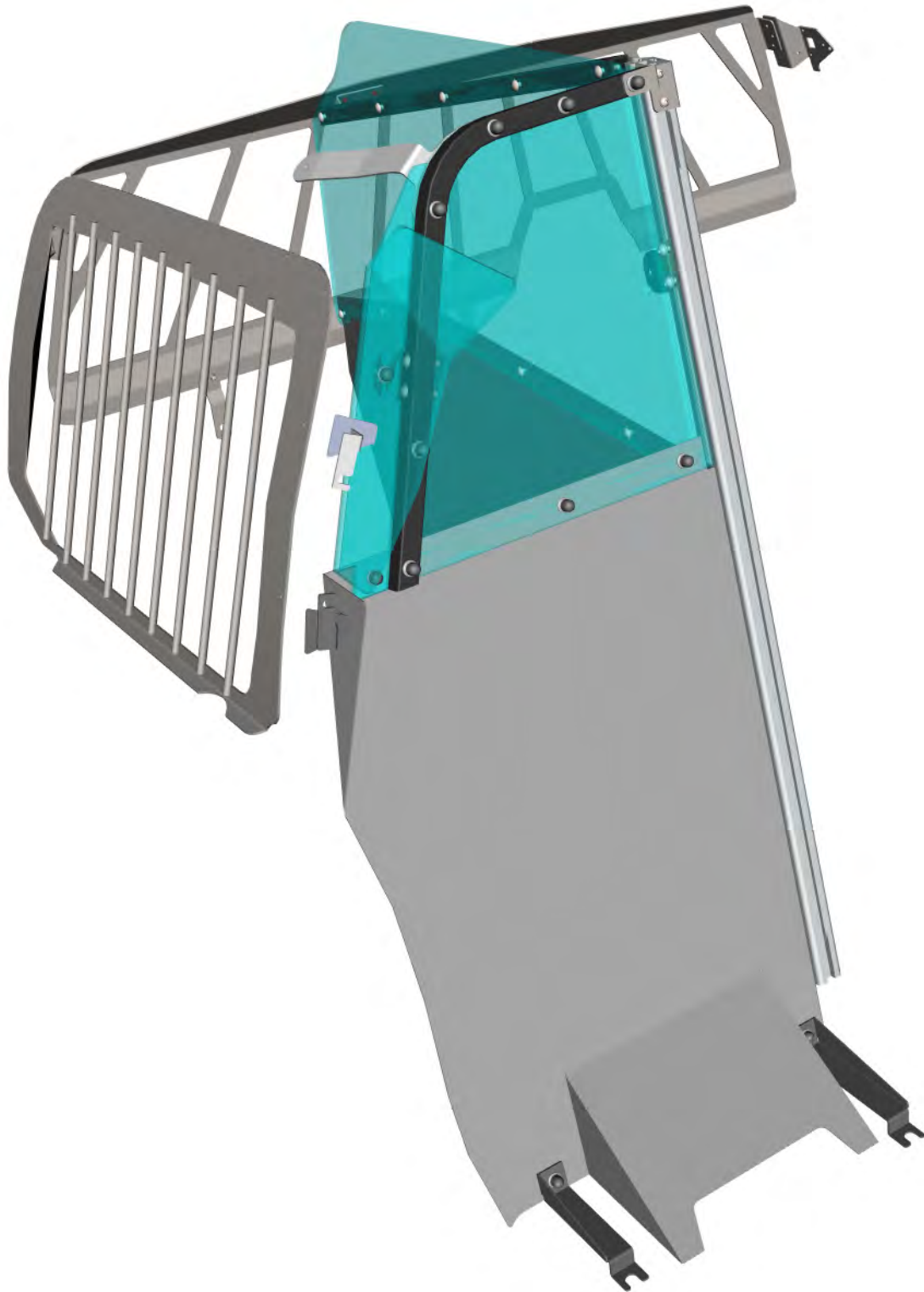

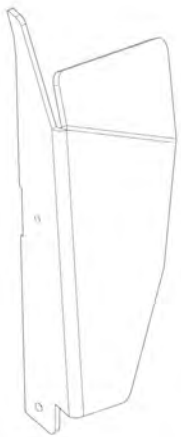

Upper Poly Wing



Headline Bracket



Upper and Lower Bracket

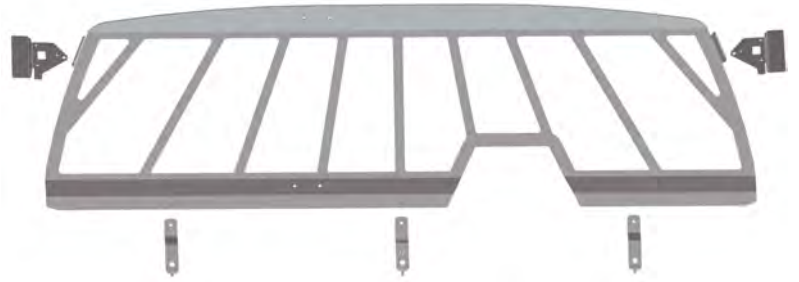

Rear Window Armor

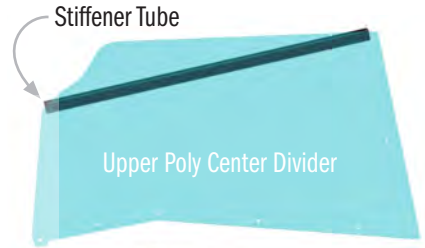

Stiffener Tube

Upper Poly Center Divider



Lower Steel Center Divider

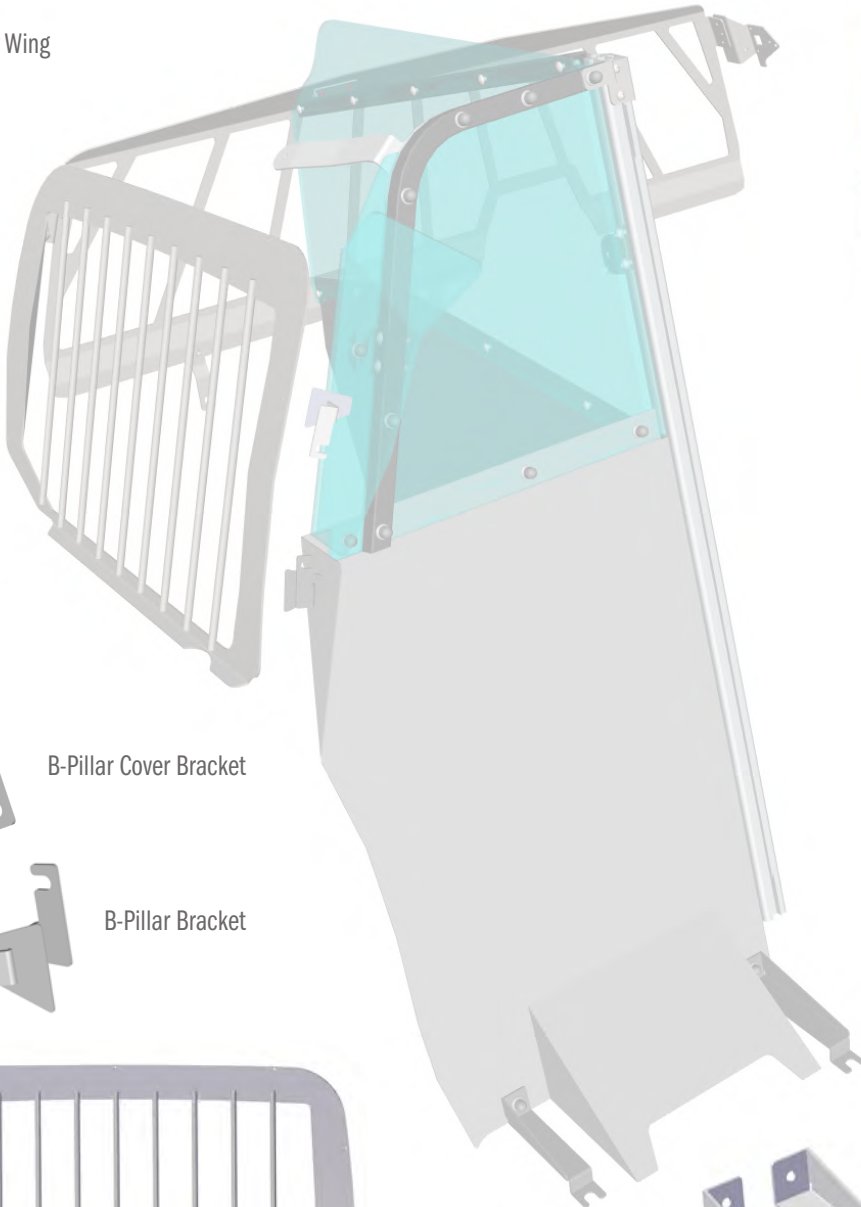

B-Pillar Cover Bracket



B-Pillar Bracket

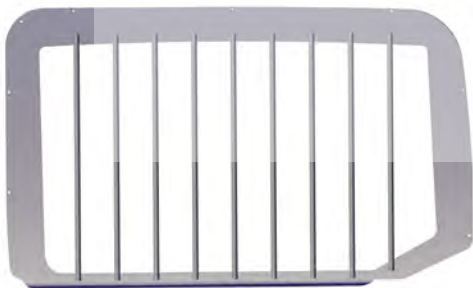

Passenger Side Window Armor



Inner Foot Mount Bracket



Assembled Front Divider

Before beginning the installation, confirm that you have received all of the parts for your package. Read the instructions completely before starting installation.

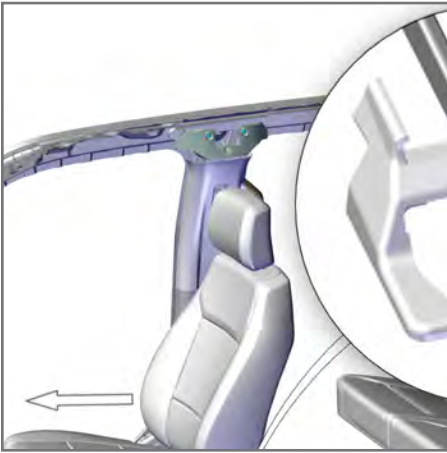

1. Slide P/S front seat completely forward. Remove rear OEM trim cover to expose the 13 mm bolts. Unscrew bolts halfway.

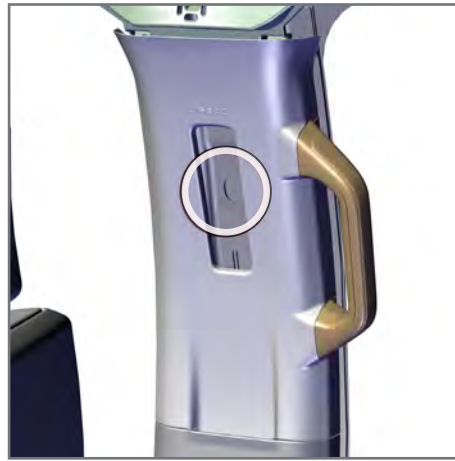

2. Remove plastic cap from the P/S B-Pillar seat belt adjuster. Use a T-45 socket to remove the OEM Torx screw.

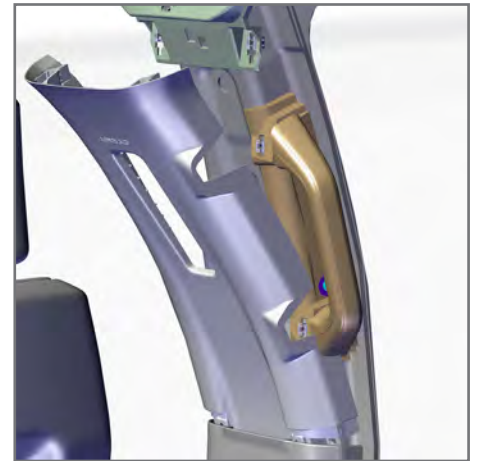

3. Pop the P/S upper B-Pillar trim loose from the grab handle side giving access to its mounting hardware. It's not necessary to fully dislodge trim from its position.

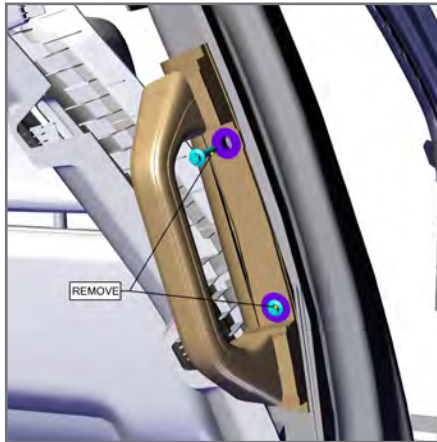

4. Remove the (2) 7 mm screws attaching the B-Pillar handle.

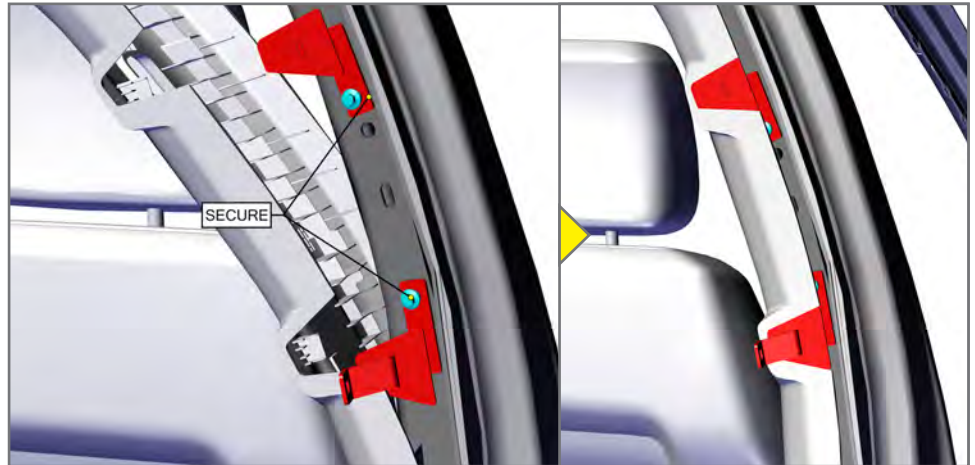

5. Using the previously removed OEM hardware, attach the provided B-Pillar Bracket and B-Pillar Cover Bracket. Re-attach B-Pillar trim and seat belt adjuster at this time.

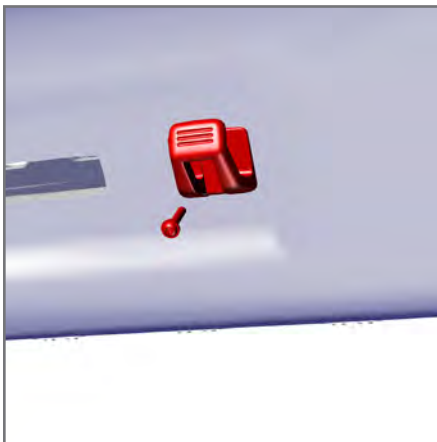

6. Remove cover from P/S headliner hook exposing the (1) T-20 Torx screw. Remove screw and set hook aside.



7. Slip the Lower Steel Center Divider between the split in rear seats.



8. Outside of vehicle, attach Inner Foot Mount Brackets to Assembled Front Divider using provided carriage bolts and flange nuts.

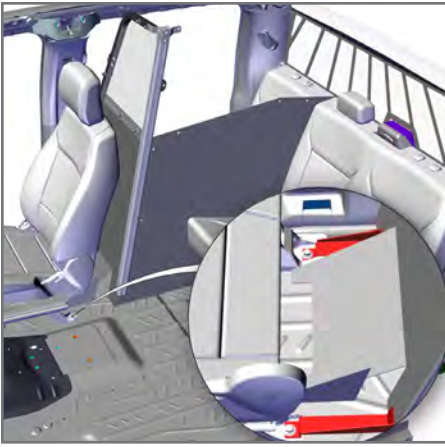

9. Install Assembled Front Divider into vehicle, slipping the Foot Mount Brackets under the previously loosened OEM seat bolts, this will require a little twisting to get into proper position.

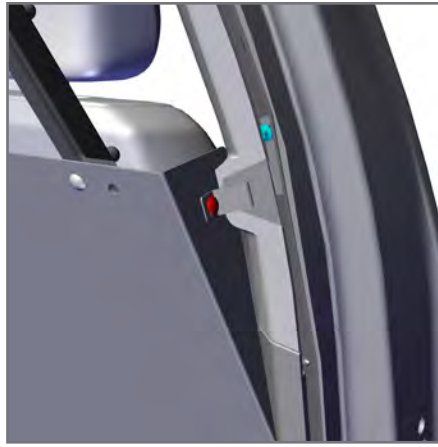

10. Loosely attach B-Pillar Bracket onto Assembled Front Divider. Use provided carriage bolt and flange nut.

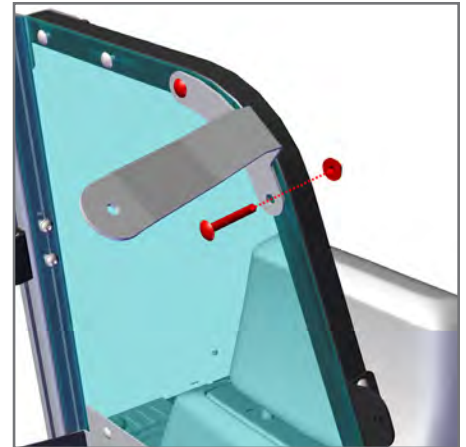

11. Loosely attach Headliner Handle Bracket onto Assembled Front Divider. Use provided carriage bolt and flange nut.

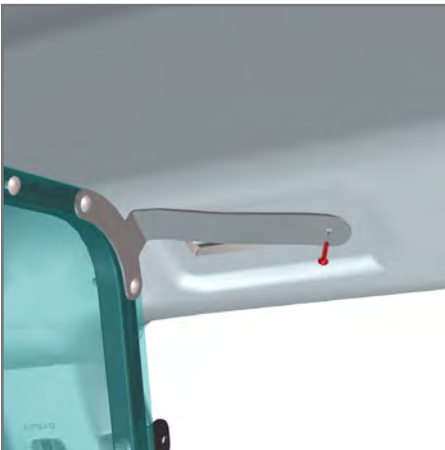

12. Loosely attach Headliner Handle Bracket onto the headliner hook location. Reuse OEM Torx screw.

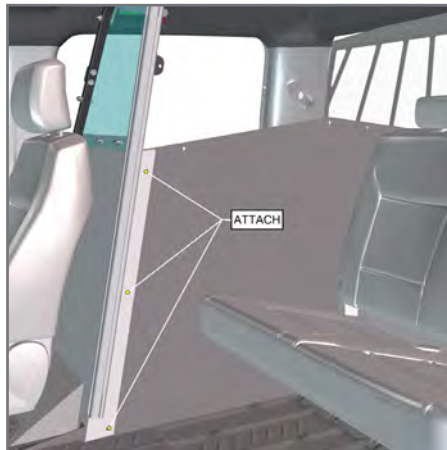

13. Loosely secure Lower Steel Center Divider onto Assembled Front Divider using provided carriage bolts and flange nuts.

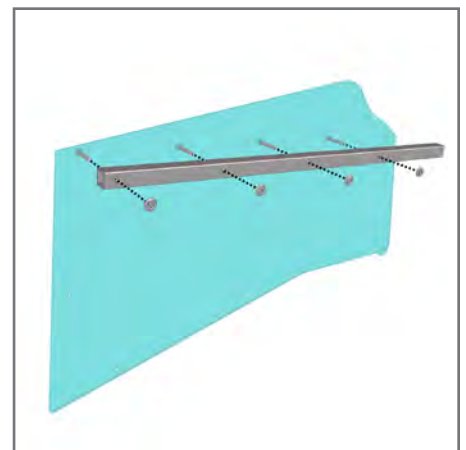

14. Outside of vehicle, attach the Stiffener Tube to the D/S Upper Poly Center Divider with provided carriage bolts and flange nuts.

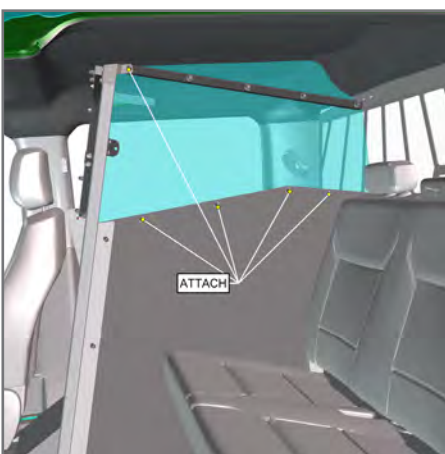

15. Attach Upper Poly Center Divider to Lower Steel Center Divider and Assembled Front Divider using provided carriage bolts and flange nuts. Tighten all bolts at this time.

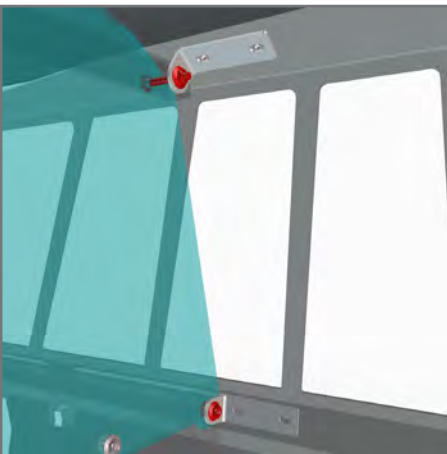

16. Attach Upper Mount Bracket to Upper Poly Center Divider and Lower Mount Bracket to Lower Steel Center Divider with carriage bolts and flange nuts.

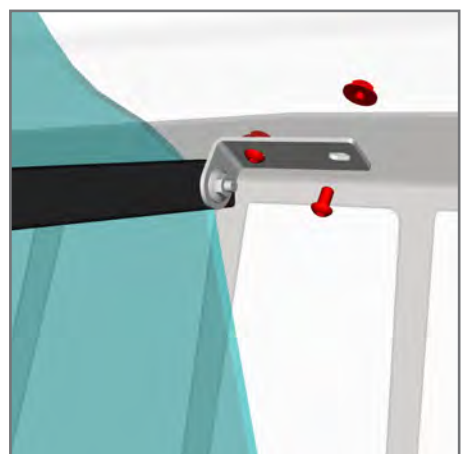

17. Secure Upper Poly and Lower Steel Center Divider by attaching Upper and Lower Mount Brackets to the Rear Window Armor with provided socket head cap screws and flange nuts.

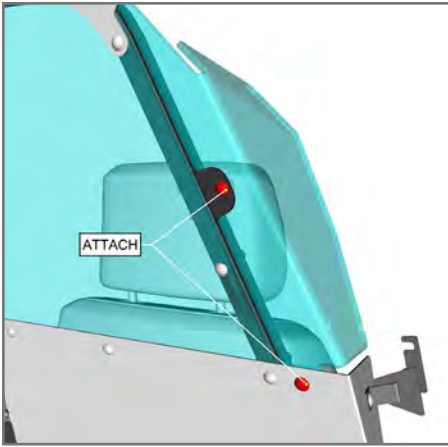

18. Install Upper Poly Wing from officer side of vehicle using provided carriage bolts and flange nuts.

If you have questions or need further assistance please call Technical Support: 1.877.455.6886



209 W. EASY ST., ROGERS, AR 72756 • JOTTOPUBLICSAFETY.COM • 10/24

Jotto Desk™ is a patented product and Registered Trademark of Assembled Products™ Corporation.
Specifications subject to change without notice.



050-0097-00