

475-2038/2049

475-2046/2050

1. Button Head Cap Screws will already be attached to T-Block and Mounting Brackets. Loosen the screws slightly. (Pic 1)
2. Place AR Lock Head Assembly into the base of Extruded Backbone of Single Cell, through notched out section on the face. Slide T-Block up the channel, finger tighten to hold in place. (Pic 2)
3. Slide Charge Guard Assembly into the base of Extruded Backbone of Single Cell, through notched out section on the face. Slide T-Block up the channel, finger tighten to hold in place. (Pic 3)
4. If Dual Weapon Mount, slide 870 Lock Head Assembly into the base section of the Backbone on the driver side through notched out section. Slide T-Block up the channel, finger tighten to hold in place.
5. Place Butt Plate/Bracket at lowest point of Extruded Backbone; AR on the face and 870 on rear channel, and completely tighten. (Pic 3) When the Butt Plates are secured, place weapon(s) into vehicle to adjust Locks/Upper Brackets into proper location. Tighten all Screws. (Be Careful Not To Overtighten and Strip The Head of Screw) (Pic 4)

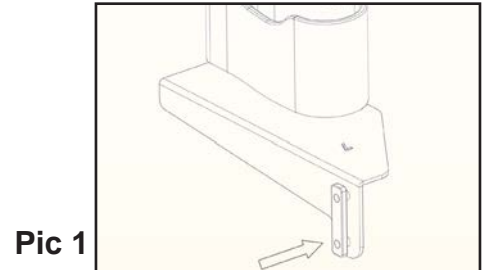

Pic 1

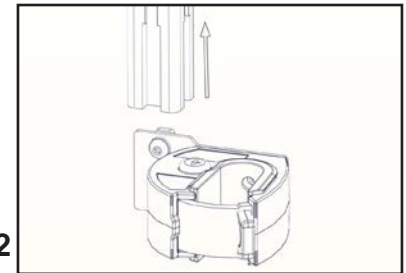

Pic 2

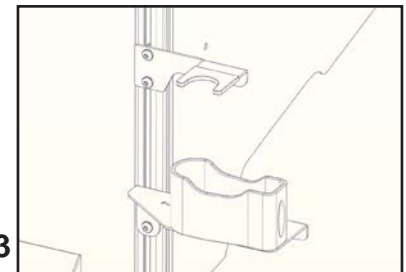

Pic 3

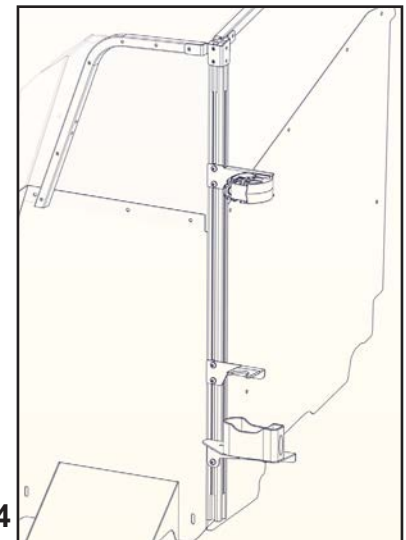

Pic 4