



SINGLE CELL LITE

2023+ CHEVROLET SILVERADO SSV

Installation Instructions

475-2070



Not Compatible with OEM Rear Underseat Storage Option

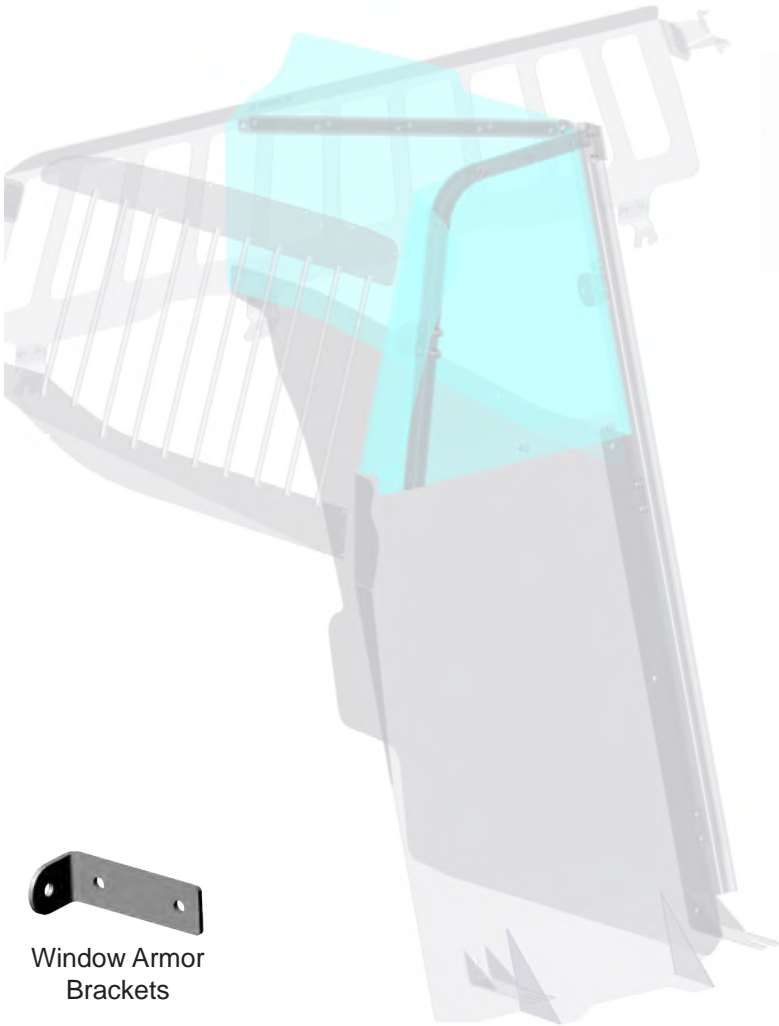

Rear Window Armor



Upper Poly Wing



P/S Door Window Armor



Window Armor Brackets



B Pillar Bracket



Inner Foot Mount Brackets



D/S Side Mount Bracket



P/S Side Mount Bracket



Lower Mount Brackets



Assembled Front Divider

Upper Poly Center Divider



Lower Steel Center Divider

*Window Armor Install

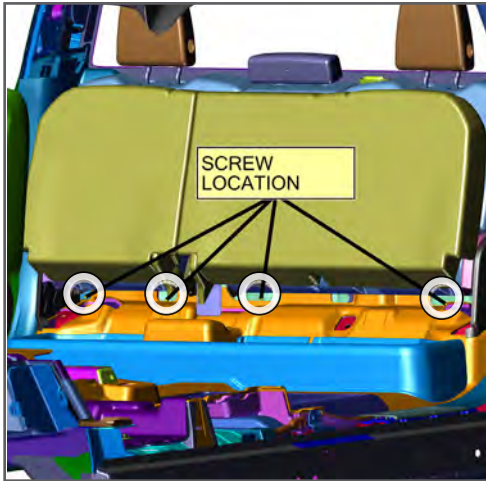

1. Lift lower rear seat cushions to access and remove (4) 10 mm bolts located on the lower section of the backseat rest. Fold seat back down.

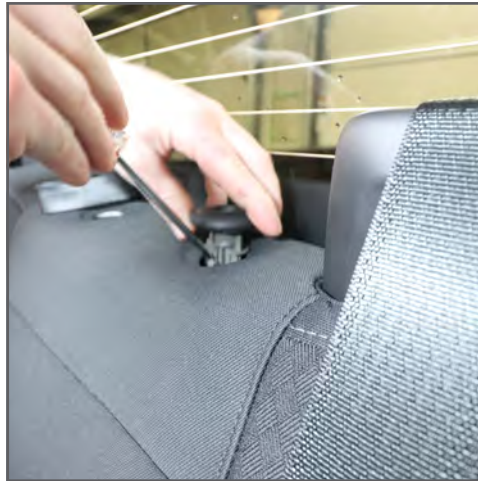

2. Remove head rest and (6) plastic head rest socket with a flat head screwdriver securing the seat to the back of the vehicle.

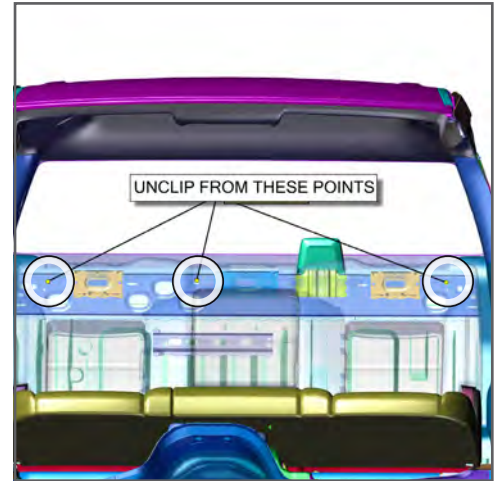

3. With a 90-degree angle pick, lift each locking tab located by the tie down straps on the rear seat. Once removed, shift entire rear seat forward.



(Close up example of using the angle pick to lift the three locking tabs from previous step.)

Angle Pick



4. Remove "C" pillar upper OEM trim. With a flat trim tool, remove seat belt socket guide (1) then the trim (2).



5. Remove the 7 mm screw attaching trim to the vehicle via nylon strap.

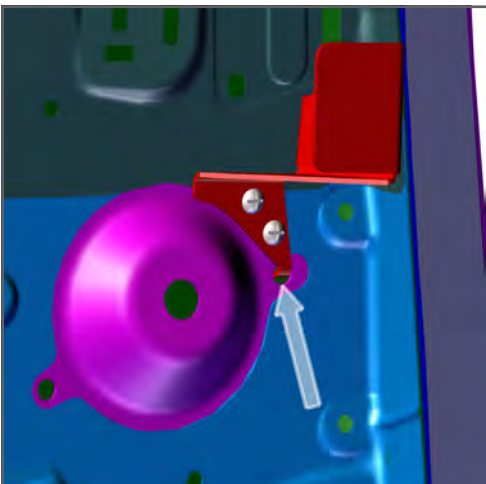

6. Attach the "P/S Armor Upper BKT" by inserting locating tab into place and secure with provide hardware. **REPEAT FOR OTHER SIDE.**



7. Replace OEM "C" Pillar Trim on top of P/S Side Armor Upper Brackets. **REPEAT FOR OTHER SIDE.**

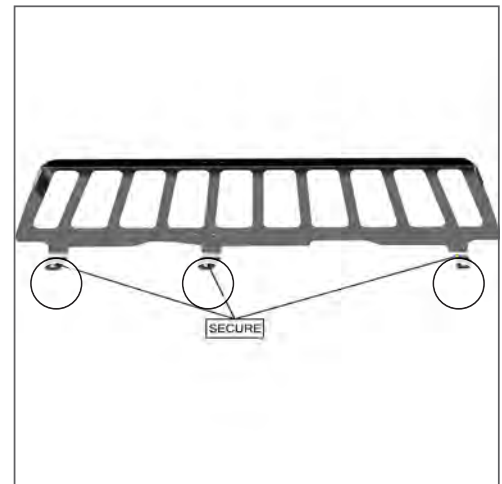

8. Loosely attach (2) P/S Lower Mount Brackets and (1) D/S Lower Mount Bracket to Rear Window Armor with provided (6) lock washers and button screws.



9. Remove (3) 18 mm bolts attaching the tie down strap locations. Insert Window Armor with Brackets (behind the rear seat locking mechanism).

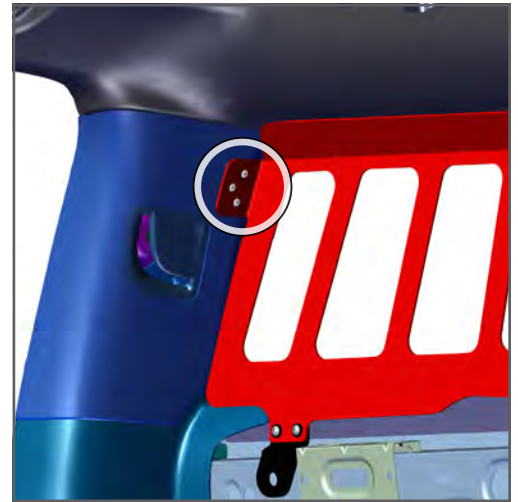

10. Pull the Window Armor forward away from the glass and secure to the DS/PS Side Mount Brackets with (6) self-tapping screws.



11. Once Window is in position, tighten all hardware. **REINSTALL REAR SEAT**



12. Align P/S Door Window Armor into position following contour of door frame. Secure Window Armor into place using provided tek-screws. ***End of Window Armor Install**

*Single Cell Install

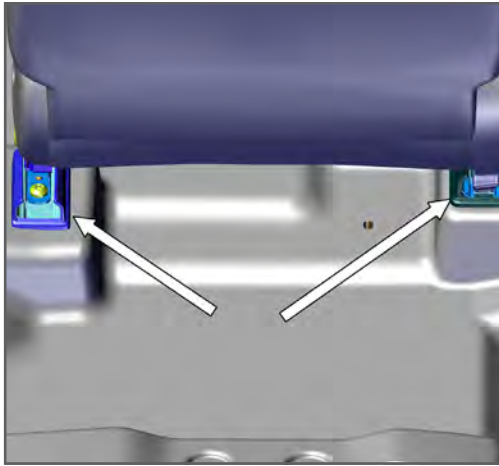

1. Move passenger seat completely forward and loosen the rear (T-50 Bolts).

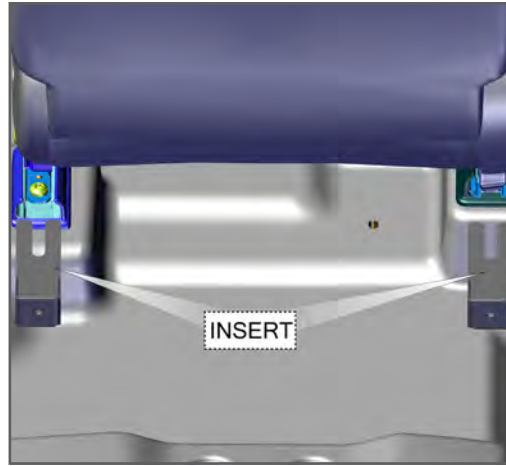

2. Push seat up slightly to slide the Inner Foot Mount Brackets under seat rails, between rail and carpet. Leave bolts loose at this time.

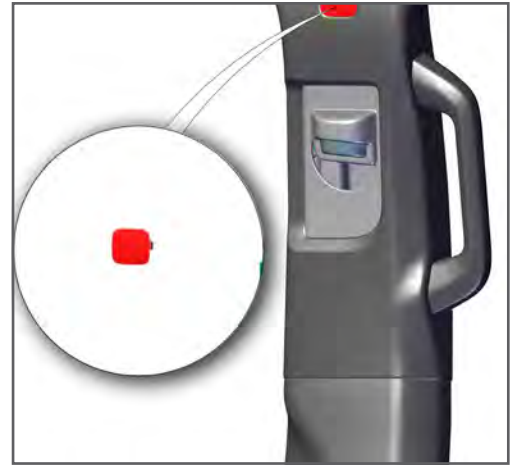

3. Remove the upper B-Pillar trim by popping out the square trim cover, giving access to the screw at the top of the headliner remove with 7mm socket. With slight pressure, pull to unclip the P/S Upper "B Pillar trim" from its location.

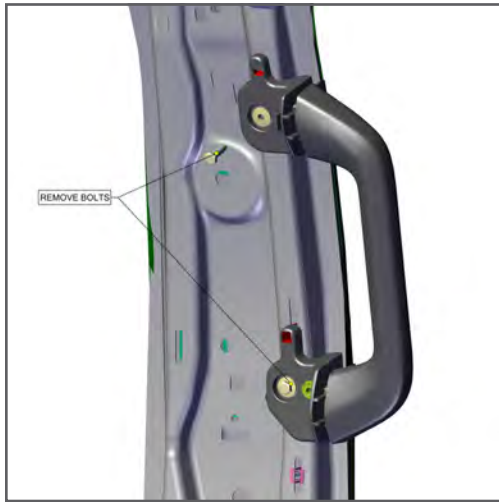

4. Utilize a 10mm socket to remove the P/S Grab Handle. **Grab Handle Not Reused.**



5. Attach the P/S B-Pillar Cover Bracket and B-Pillar Bracket with previously removed 10 mm bolts. Replace upper B-Pillar trim and previously removed screw.



6. Slip the Lower Steel Divider between split in rear seats.

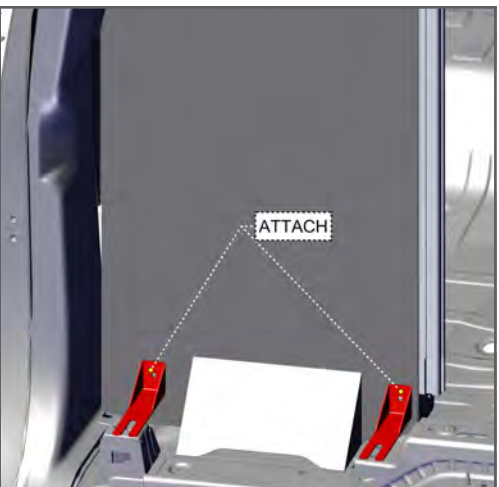

7. Install Assembled Front Divider into vehicle. This will require a little twisting to get into proper position. Bolt down Inner Foot Mount Brackets to Assembled Front Divider with provided carriage bolts and flange nuts. Tighten previously loosen rear seat (T-50 Bolts.)

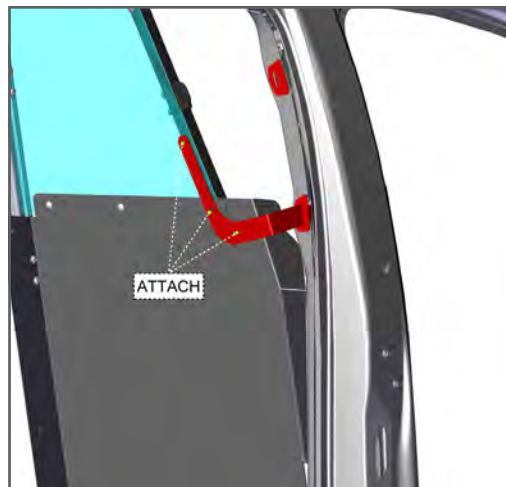

8. Loosely attach B-Pillar Bracket onto Assembled Front Divider and Upper Support Tube. Use provided carriage bolts and flange nuts.

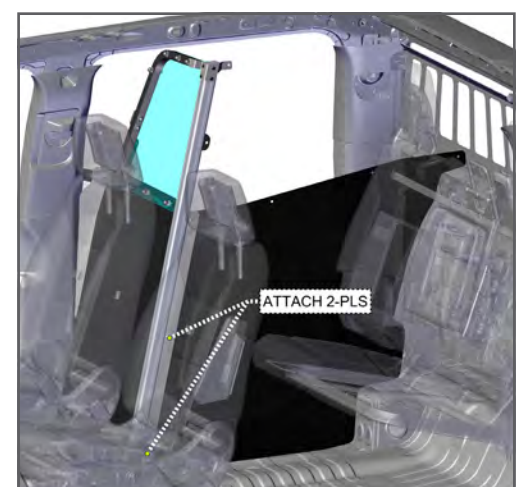

9. Loosely secure Lower Steel Center Divider onto Assembled Front Divider with carriage bolts and flange nuts.

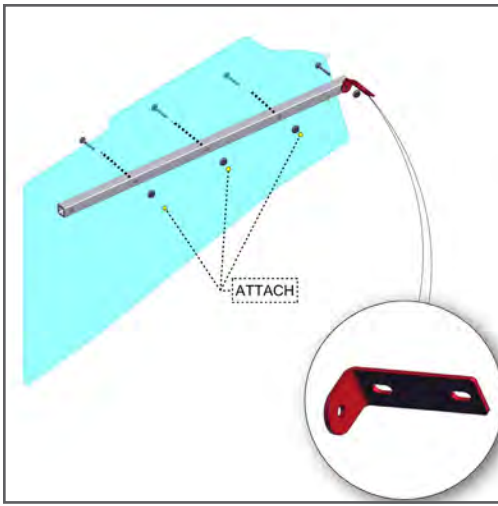

10. Outside of vehicle, attach Stiffener Tube and Window Armor Bracket to Upper Poly Center Divider with provided carriage bolts and flange nuts.

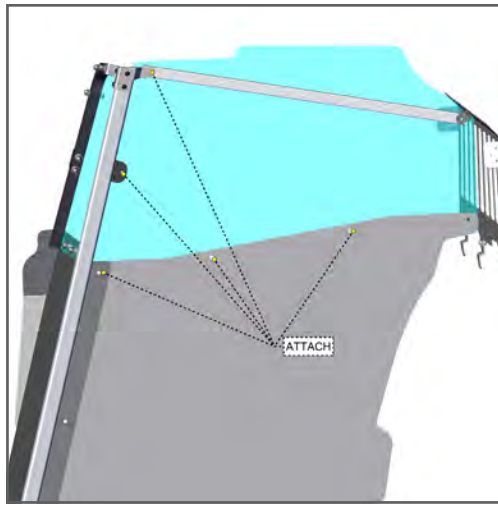

11. Attach Upper Poly Center Divider to Lower Steel Center Divider and Assembled Front Divider from P/S side using provided carriage bolts and flange nuts. Tighten all bolts at this time.

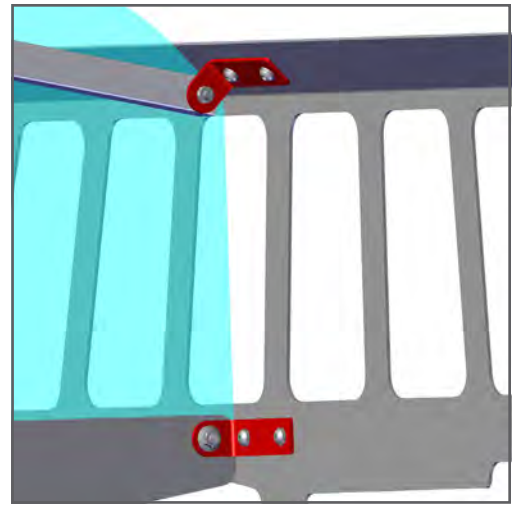

12. Secure Upper Poly Center Divider / Lower Steel Center Divider with Wire Grid Brackets to the Rear Window Armor with provided Socket Head Cap Screws.

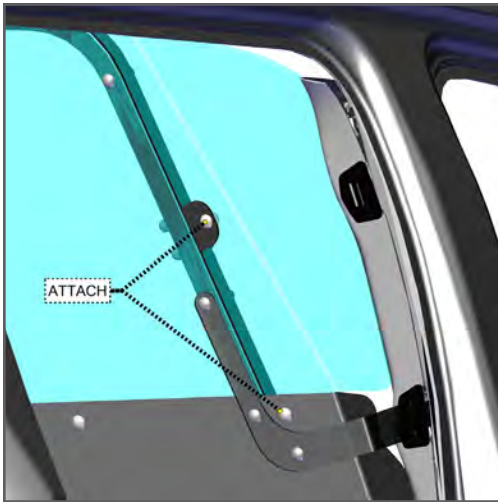

13. Install Upper Poly Wing from officer side and secure with provided carriage bolts and flange nuts. Install cap nut covers on all flange nuts.

